

Smart Radar Level Transmitter

Model: MDRA6



I. Product Overview

1.1 Introduction

MDRA6 radar level meter is an 80GHz high-frequency intelligent level measuring instrument, which outputs (4~20) mA analog signal, with a maximum range of 35 meters. The antenna is further optimized, and the new fast microprocessor can perform signal analysis and processing at a higher rate, so that the instrument can be used for level measurement of liquid tank, solid silo and other general working conditions.

1.2 Principle

The radar level meter transmits a continuous radar wave signal from the antenna. This signal is FM continuous wave, or FMCW for short. There is a frequency difference between the continuous wave transmitted from the radar level meter antenna and the echo returned from the object surface. The frequency difference is proportional to the distance between the antenna and the object surface. After receiving the echo, the electronic components use special processing such as Fast Fourier Transform (FFT), and use a unique high-precision algorithm, The instrument can accurately measure the level height.

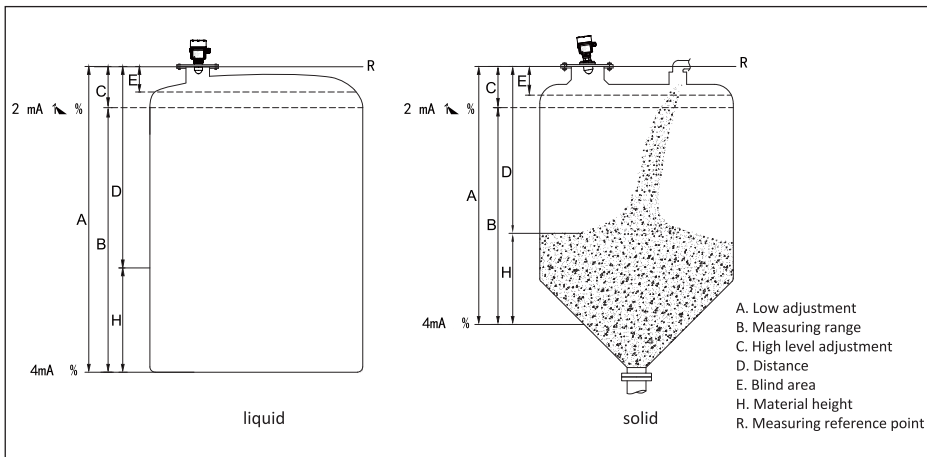

figure 1

1.3 Features

- ▶ The radar level meter adopts the working frequency of 80GHz and has the following characteristics:
- ▶ Non contact measurement, no wear, no pollution;

- ▶ Small antenna size, easy to install;
- ▶ Shorter wavelength, better reflection on inclined solid surface;
- ▶ The measurement blind area is smaller, and good results will be achieved for small tanks;
- ▶ The beam angle is small and the energy is concentrated, which not only enhances the echo ability, but also helps to avoid interference;
- ▶ It is almost not affected by the changes of water vapor, temperature and pressure in the atmosphere;
- ▶ 80GHz frequency is the best choice for measuring solid and low dielectric constant medium, which is satisfied with the dielectric constant of the measured medium

2.Product Introduction



MDRA6

Features: solid/liquid can be measured, with angle measurement function, simple installation, high precision, strong anti-interference ability and small beam angle.

Application: applicable to general working conditions, such as liquid level height measurement in water industry, level height measurement of small range solid silo.

Measuring range: 10m/20mm/35m

Precision: ± 2 mm

Process connection: G1 1/2 "A

Process temperature: - 40~80 C

Process pressure: - 0.1~0.3Mpa

Frequency range: 80GHz

Signal output: 4~20mA/24V DC two-wire system

4~20mA/24V DC/HART two-wire system

Bluetooth function: optional

Explosion proof grade: Exia IIC T6 Ga

Protection grade: IP67

3. Installation

Please pay attention to the following items to ensure that the instrument can be installed correctly.

1. Please reserve enough space for installation.
2. Please avoid installation occasions with strong vibration.

3.1 Installation position

- ▶ The instrument shall be installed at $1/6$ or $1/4$ of the tank diameter.
- ▶ If the tank diameter is small, the minimum installation distance is $\geq 200\text{mm}$.

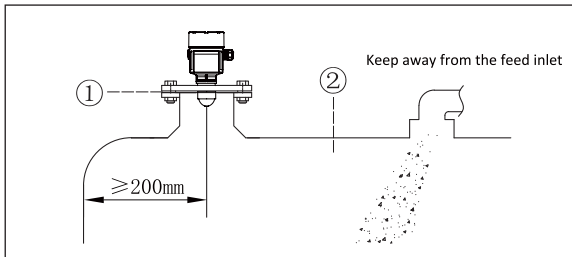

figure 2

Note:

- ① Datum plane
- ② Center of container or axis of symmetry

- ▶ The conical flat roof tank is installed in the middle of the tank top and can be measured to the bottom of the conical tank.

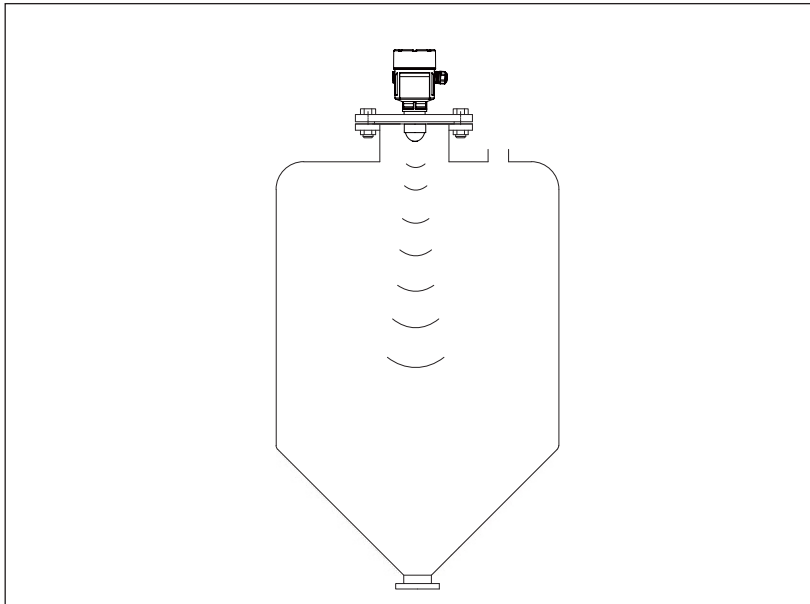

figure 3

- For the storage tank with material pile, the antenna shall be vertically aligned with the slope. If the slope is uneven and the pile angle is large, universal flange must be used to adjust the angle of the conical antenna so that the conical antenna can be aligned with the slope as much as possible.

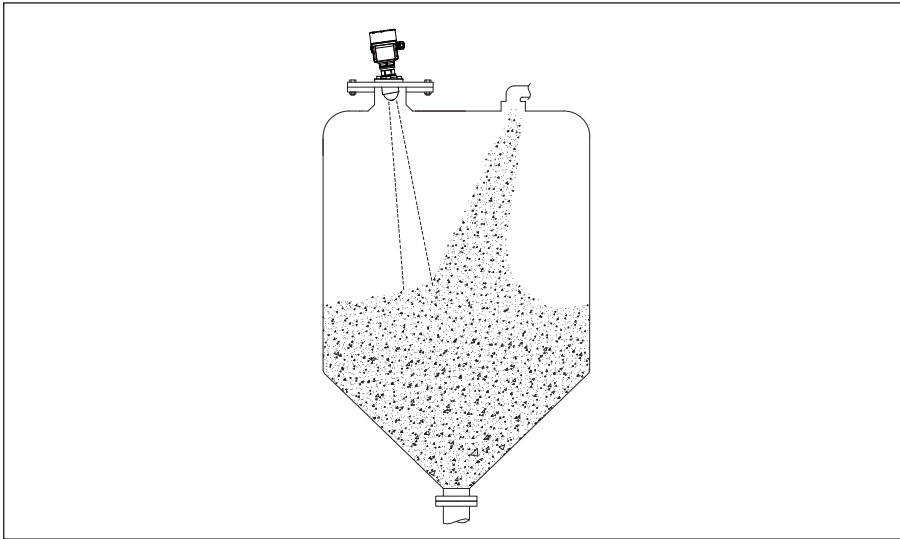

figure 4

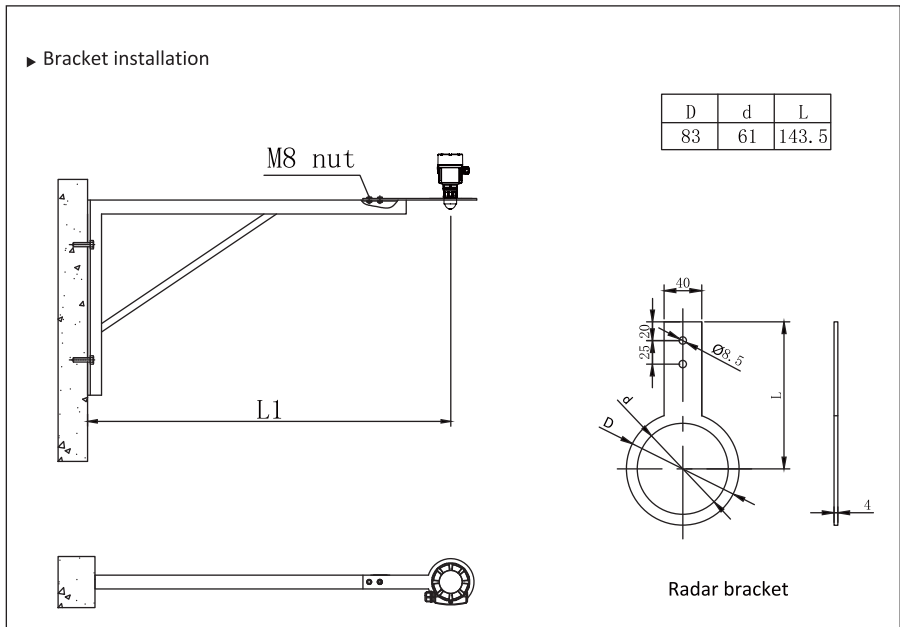

figure 5

3.2 Typical wrong installation

- It cannot be installed above the feed inlet.

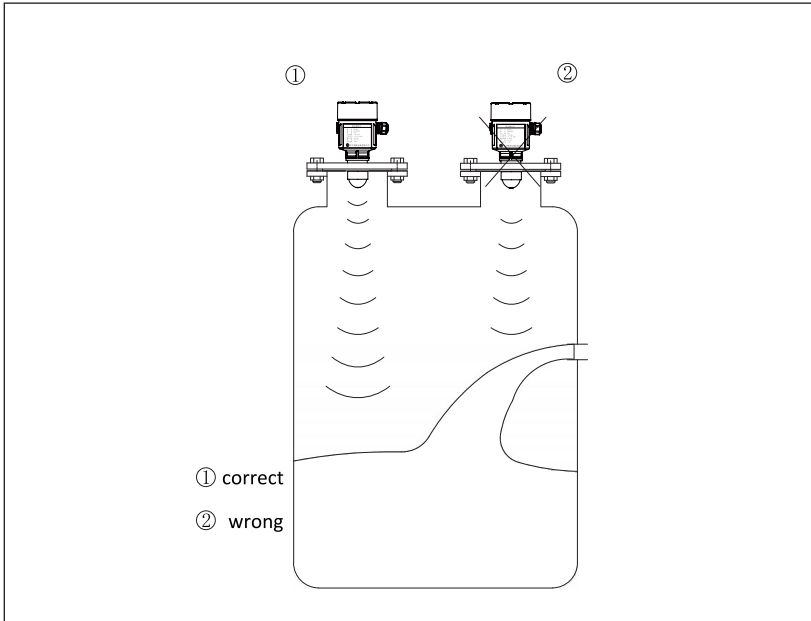

figure 6

- The instrument cannot be installed in the middle of the arc tank top, which will be affected by multiple echoes. Since the arc tank roof can concentrate multiple echoes, and the multiple echoes may be stronger than the real echo signal, it cannot be installed in the center.

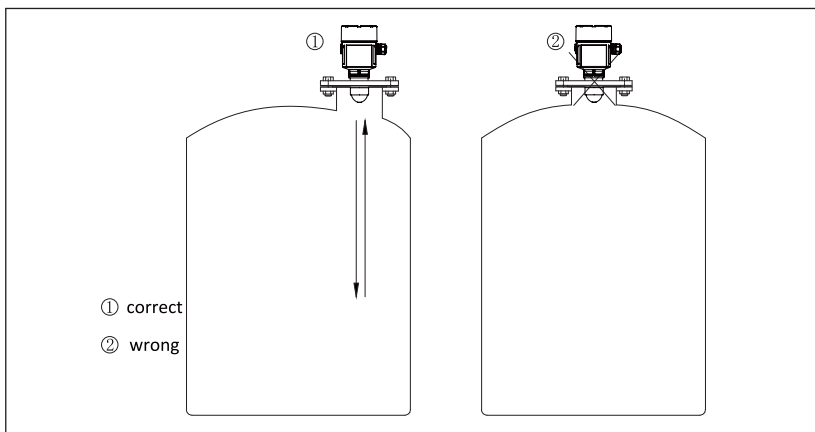

figure 7

3.3 Tank nozzle

► It is strongly recommended that the length of vessel installation nozzle on site should be $\leq 200\text{mm}$, and it is a very reasonable installation method that the length of vessel installation nozzle should be $\leq 200\text{mm}$.

► If the length of the vessel connecting pipe is long, please refer to Figure 8. The longest installed connecting pipe shall be as small as possible as the size shown in Figure 8, and the end must be ground smooth without burrs and other protrusions. If necessary, use the "false echo storage" function to eliminate the reflected signal at the end of the container nozzle, which can also achieve better measurement results.

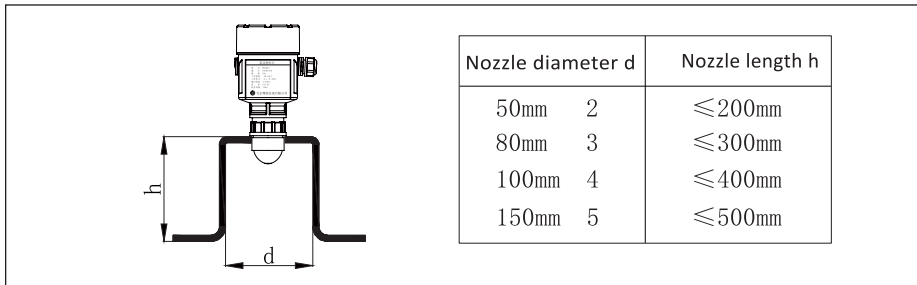

figure 8

3.4 Launch angle and false reflection

The transmitting angle of the radar level meter depends on the antenna size.

If the transmitted radar signal can reach the surface of the medium vertically and there is no device in the container to block and reflect the signal, this measurement condition is the best.

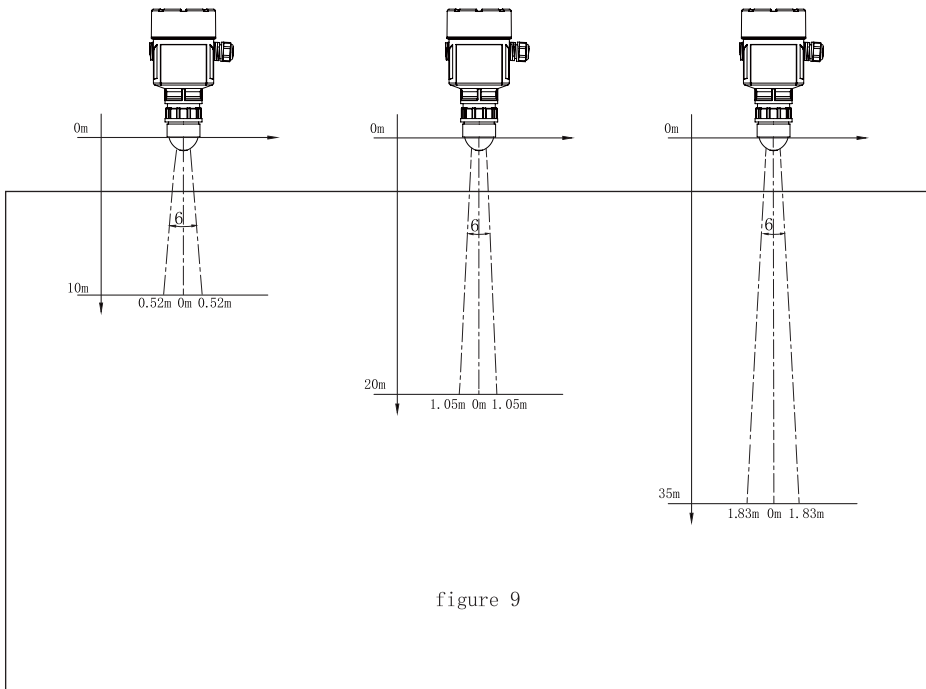

figure 9

4. Electrical Connection

4.1 Supply voltage

(4~20) mA/HART (two-wire system) power supply 24V DC

The power supply and output current signal share a two core shielded cable. For intrinsically safe type, a safety barrier must be added between the power supply and the instrument.

4.2 Installation of connecting cable

Cable outer diameter: 6~9mm (M20 × 1.5) 3.5mm~8.7mm(½ NPT)

Shielded cables are generally used for wiring.

(4~20) mA/HART (two-wire system) power supply cable can use two core cable

4.3 Cable shielding and wiring

Ideally, the shield wire should be grounded at both ends. However, it should be noted that there will be grounding compensation current. When both ends are grounded, a capacitor with grounding potential can be connected at the grounding end (such as in the switch cabinet). (For example: 1 μ F; 1500V). The grounding with the lowest resistance shall be adopted. (Note: If the instrument is used in explosion-proof area, due to potential output, both ends must not be grounded)

4.4 Wiring mode

(1) 24VDC power supply, 4-20mA output

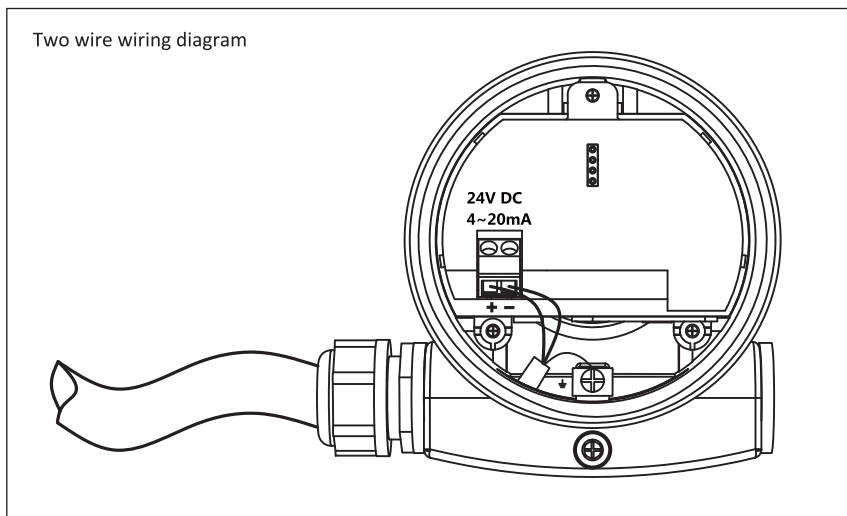

figure 10

Explosion proof connection:

The explosion-proof type of this product is intrinsically safe. Explosion proof sign: Exia II C T6 Ga. This product is applicable to the continuous level measurement of combustible media below the explosion proof level of Exia II C T6 Ga.

This product must be powered by a safety barrier. The safety barrier is the associated equipment of this product, and the explosion-proof type is intrinsically safe. Explosion proof sign: [Exia Ga] IIC, power supply voltage 24V DC, short circuit current 100mA, working current (4~20) mA.

All cables shall be shielded cables, and the maximum length from the instrument to the safety barrier is 500m. $U_i=30VDC$, $I_i=100mA$, $P_i=0.75W$, $C_i=0\mu F$, $L_i=0mH$ The radar level meter must be grounded during installation. Other related equipment without explosion-proof inspection shall not be used.

Intrinsically safe explosion-proof wiring diagram:

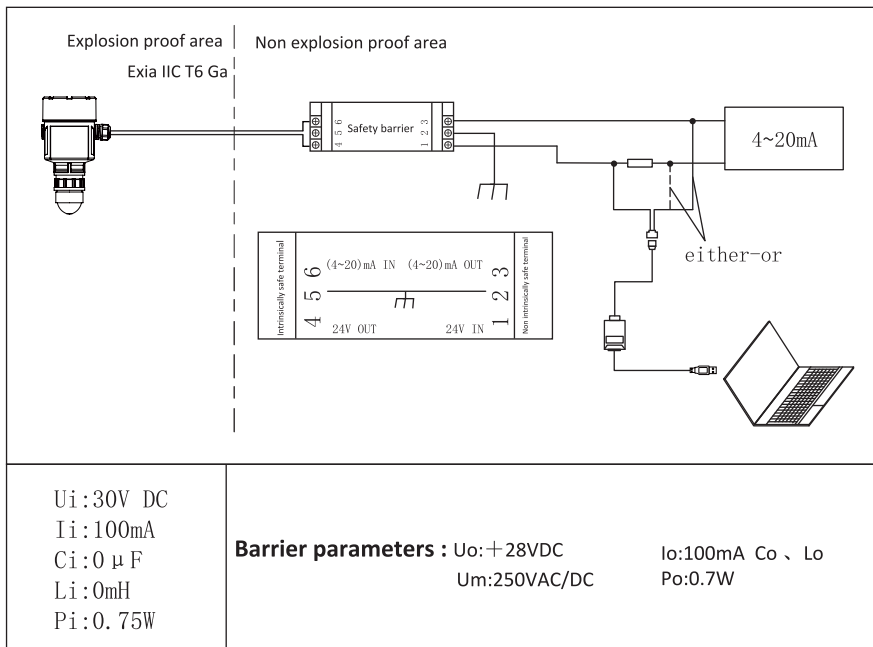

figure 11

The distribution parameters of the connecting cable between the safety barrier and the level meter shall meet the following requirements:

$$U_o \leq U_i \quad I_o \leq I_i \quad P_o \leq P_i \quad C_o \geq C_c + C_i \quad L_o \geq L_c + L_i$$

Note:

- U_o : maximum output voltage of safety barrier
- C_o : maximum external capacitance of safety barrier
- C_c : Maximum allowable distributed capacitance of connecting cable
- C_i : maximum internal capacitance of level meter

- I_o : maximum output current of safety barrier
- L_o : maximum external inductance of safety barrier
- L_c : Maximum allowable distributed inductance of connecting cable
- L_i : Maximum internal inductance of level meter

4.5 Safety guidance

All electrical connection work must be carried out under the condition of power failure. Please follow the instructions in the instrument manual!

Please observe the requirements of local electrical installation regulations.

Please observe the local requirements for personnel health and safety regulations. All operations on the electrical components of the instrument must be completed by professionals who have received formal training.

Please check the nameplate of the instrument to ensure that the product specifications provided meets your requirements. Please ensure that the supply voltage is consistent with the requirements on the nameplate of the instrument.

4.6 Protection grade

MDRA6 radar level meter fully meets the requirements of protection grade IP67. Please ensure the waterproof of cable sealing head. As shown in the right figure:

How to ensure that the installation meets the requirements of IP67:

Make sure that the sealing head is not damaged

Please ensure that the cable is not damaged.
Please ensure that the cable used meets the requirements of the electrical connection specification. Before entering the electrical interface, bend the cable downward to ensure that water will not flow into the shell, see ①

Please tighten the cable sealing head, see ②

Please tighten the unused electrical interface with blind plug, see ③

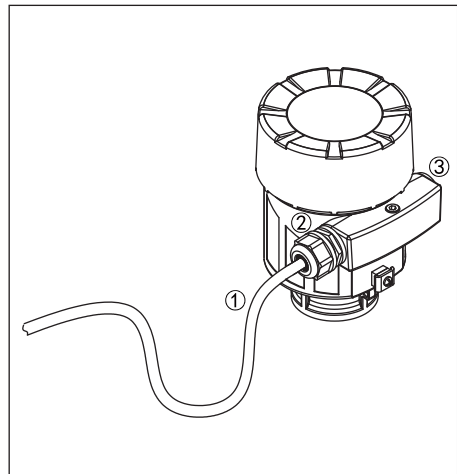

figure 12

5. Technical Parameters

General data

Product model	MDRA6
Process connection	thread G1½"A
weight	700g
Process temperature	-40~80 C
Antenna material	ABS/PTFE
Shell material	ABS
Degree of protection	IP67

Supply voltage	Two-wire system	Standard	16~26V DC
		Intrinsically safe	21.6~26.4V DC
		power waste	Max. 0.54W
		Allowable ripple	-<100Hz U _{ss} <1V -(100~100k)Hz U _{ss} <10mV
Cable parameters	Cable entry	1 *M20 × 1.5 Cable inlet (cable diameter 6~9mm) 1 *blind plug M20×1.5	
Output parameters	output signal	4~20mA/HART	
	resolving power	1.6 μA	
	Fault output	20.5mA, 22mA, 3.9mA	
	Damping time	0~100s Adjustable	
Housing	Enclosure seal	Fluorine glue	
	Upper cover window	PC	

characteristic parameter

Product model	MDRA6	
range	10m/20m/35m	
accuracy	± 2mm	
blind area	0. 05m	
General parameters	Microwave frequency communication interface	77~81GHz HART communication protocol
	Measurement interval	About 1 second (depending on parameter settings)
	Adjust time	About 1 second (depending on parameter settings)
	Vibration resistance	Mechanical vibration 10m/s ² , (10~150) Hz
	Non repeatability	≤ 1mm (already included in the measurement deviation)
	Display resolution	1mm
	relative humidity	< 95%

6 Commissioning



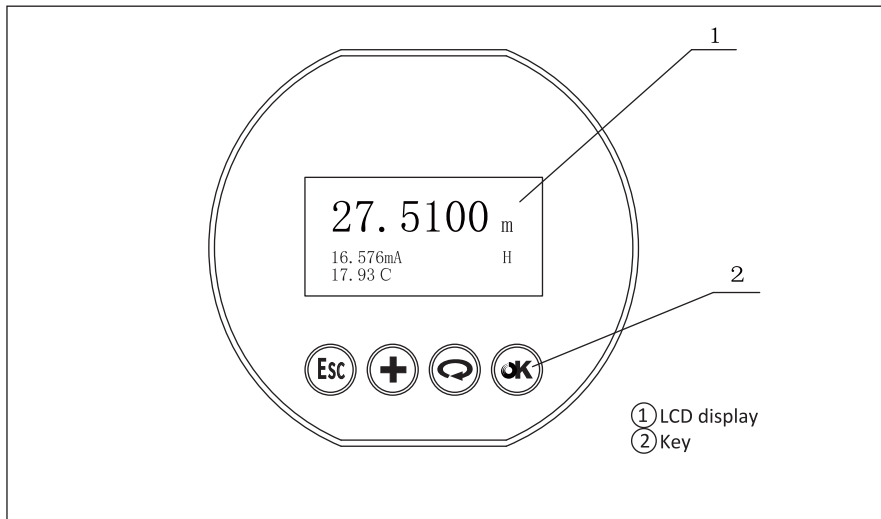

6.1 Programmer debugging

6.1.1 Key function

Debug the instrument through the 4 keys on the programming module. The language of the debug menu is optional. After debugging, it is generally only used for display, and the measured value can be read out clearly through the glass window.



Key functions

 key	<ul style="list-style-type: none"> -Exit the programming state or go back to the previous menu -Switch between display value and echo curve interface (at home page)
 key	<ul style="list-style-type: none"> -Toggle menu items -Change cursor position -Modify parameter value, 0~9 infinite loop -Toggle the curve display mode or home page display mode
 key	<ul style="list-style-type: none"> -Toggle menu items -Change cursor position
 key	<ul style="list-style-type: none"> -Enter programming state -Confirm programming items -Confirm parameter modification

sheet 1

6.1.2 Commissioning steps

(1) Enter the main menu

In the running state, pressing key **OK** will display the programming main menu. There is a triangle cursor on the left side of the main menu. Press key  to change the triangle cursor position downward, and press key **+** to change the triangle cursor position upward, Press key **OK** to enter the menu pointed by the cursor, and press key **ESC** to exit the current menu

The display interface is as follows:

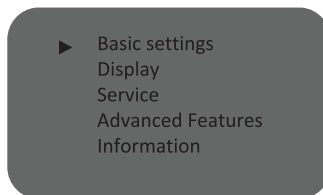

(2) Set range

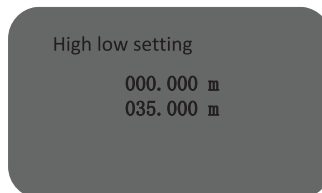

Enter the "Basic Setting" menu, and the programmer will directly display the first submenu "High Low Setting". The display interface is as follows:

For example:

- ① In general, if the distance from the measuring reference point to the tank bottom is 35m, the "low position" should be set to 35.000m; "High position" 00.000m.
- ② Under special circumstances, the field production process needs to set the maximum output below the zero point of the instrument.

For example, if the 10m tank process requires that the tank is full when the material is injected 2m below the zero point of the instrument to prevent danger, the "low position" should be set as 10.000m, and the "High position" should be set as 02.000m.

The display interface is as follows:

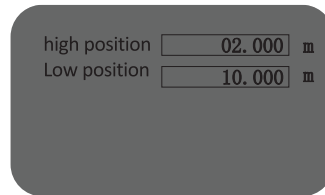
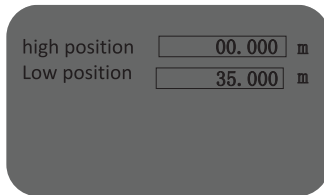

After the high position adjustment setting is completed, continue to cycle the submenu until the item "measuring range" is displayed. Note that this range is not the output range of the instrument, but the maximum range for the instrument to process the reflected echo (set value: range setting \geq low adjustment).

For example, the process requirement starts from the tank bottom, and the output range is 10m. If the "measuring range" is set to 9m, the "low level" is set to 10m, and the "high level adjustment" is set to 0m. The output range of the instrument has not changed, but the material level of 1m at the bottom of the tank can not participate in the measurement, and the instrument can not find the signal at the bottom of the tank when the tank is empty, which is easy to cause value jump.

(3) Blind zone setting

When there is a fixed obstacle near the surface of the distance sensor that interferes with the measurement, and the maximum material height will not reach the obstacle, it can be used for the blind zone setting function to avoid measurement errors. Press **OK** to enter the blind zone setting and editing interface, select+ or  key to set parameters, and press **OK** to confirm.

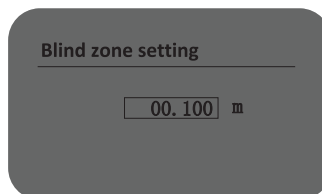

(4) Set display content

After entering the "Display" menu, the first submenu is "Display Contents". After setting the options, the instrument programmer will display the corresponding contents. The factory default value is generally the material level, that is, the height of the material level displayed on the panel when the programmer has not entered any menu.

The display interface is as follows:

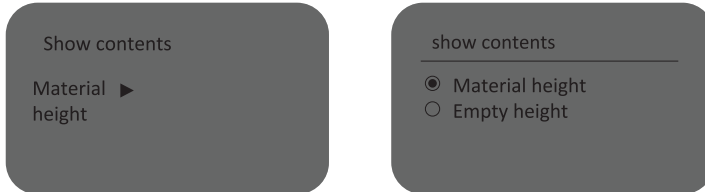

Definition of display content:

- ① Space height: measure the distance from the reference point to the medium surface;
- ② Material level: material level height, which is equal to "low level" minus "empty height"

(5) False echo storage function

The false echo storage function can eliminate the influence of interference wave on the real signal under certain conditions.

Enter the "Service" menu. The first submenu is "False Echo". Click OK to enter the setting interface, where four options are displayed.

The display interface is as follows:



(6) Select current output

After the setting of "false echo" is completed, press the key to cycle the menu to display "current output".

The display interface is as follows:

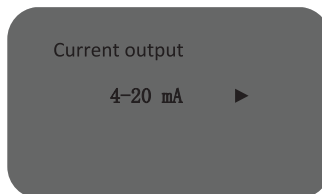

Current output: the current output direction can be selected when the instrument is working. The factory default setting is 4-20mA, and the output current is proportional to the material height; After 20-4mA is selected, the output current is inversely proportional to the material height, that is, the output current is proportional to the space height.

Schedule

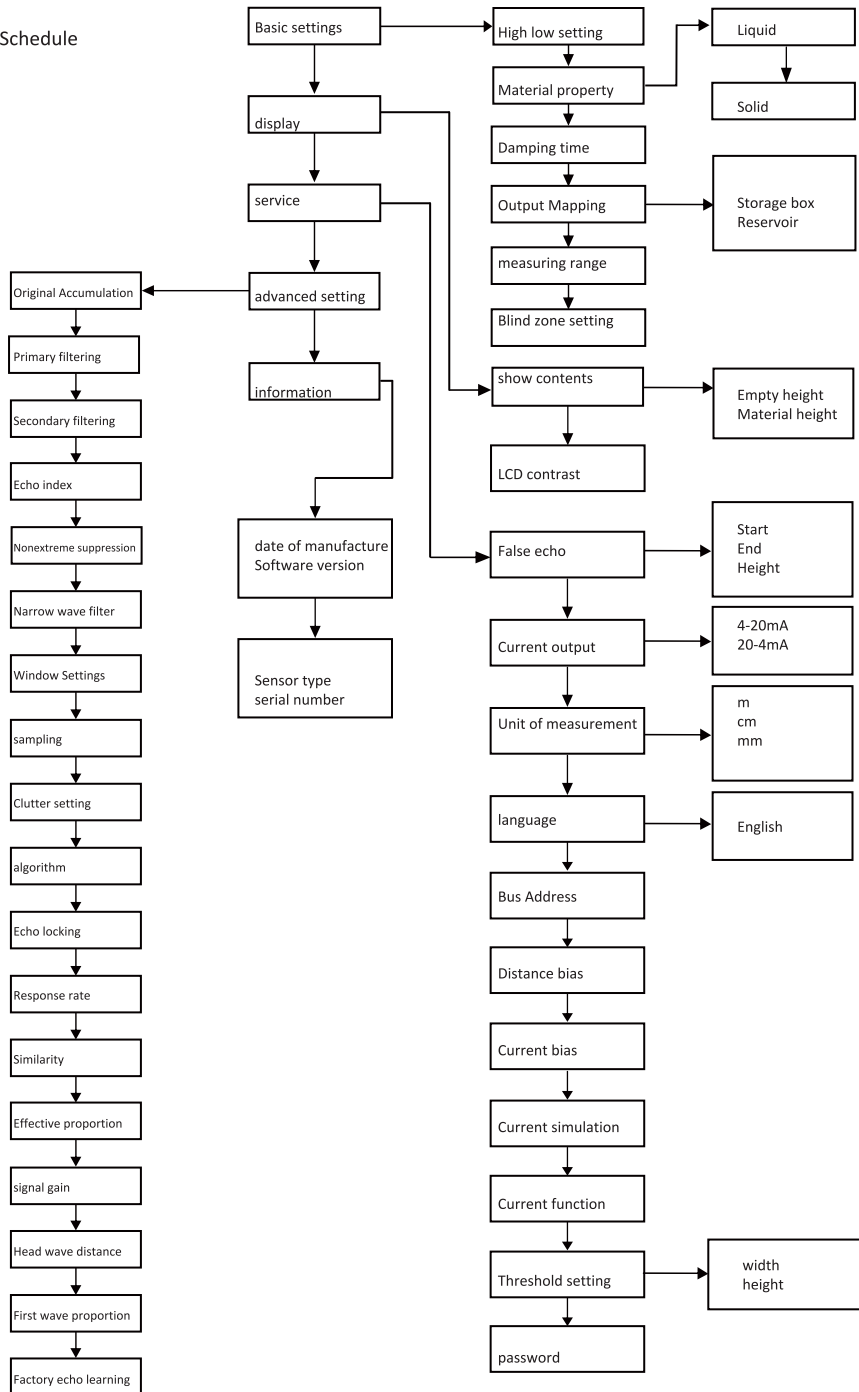

6.2 Upper computer software debugging

6.2.1 Connecting with upper computer through HART

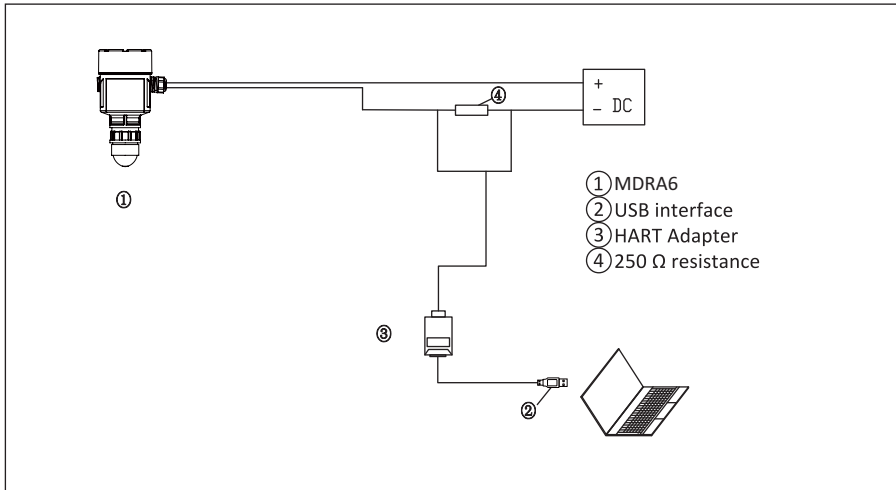

figure 14

6.2.2 Commissioning of HART handheld programmer

MDRA6 can be programmed with HART handheld programmer

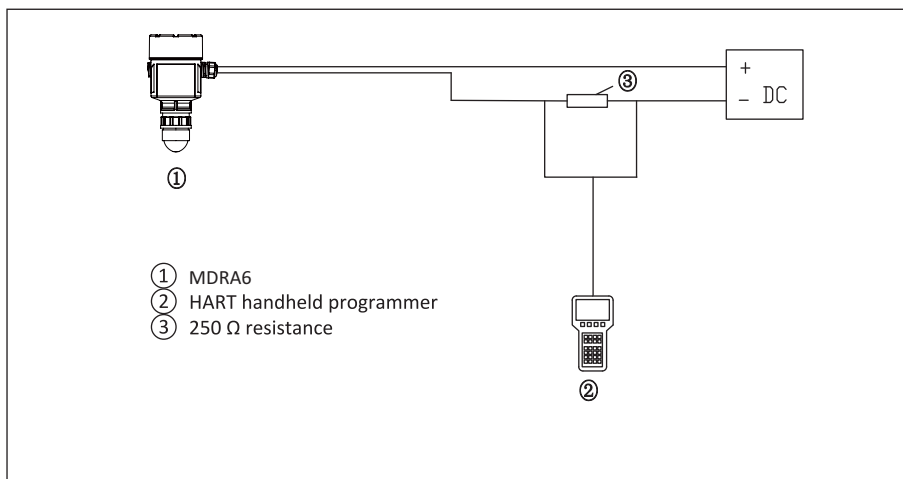

figure15

6.2.3 Bluetooth debugging

MDRA6 can be debugged with Bluetooth function

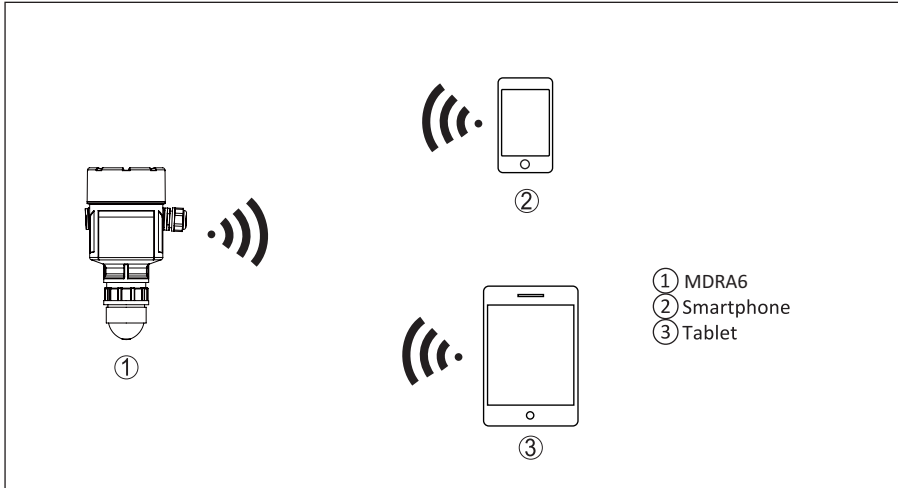
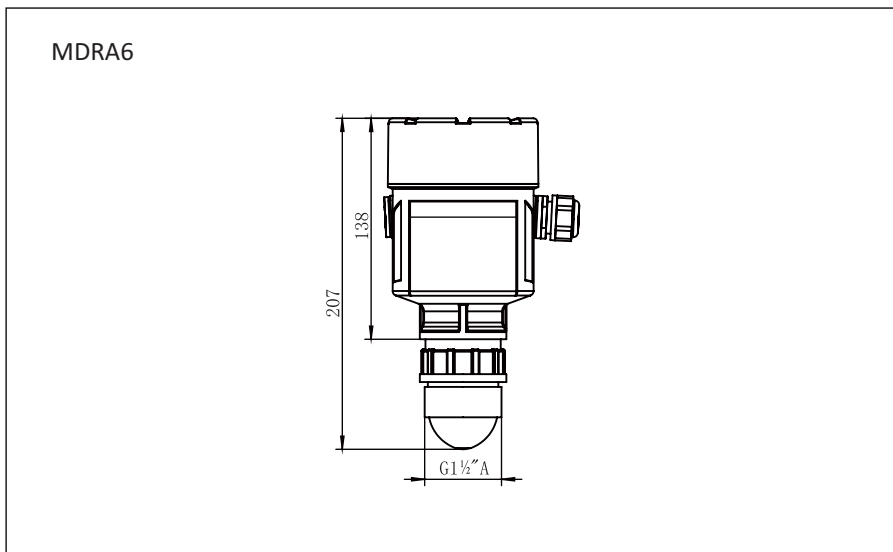
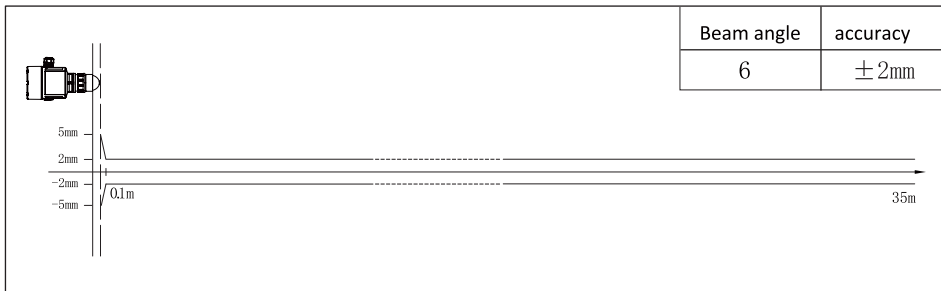
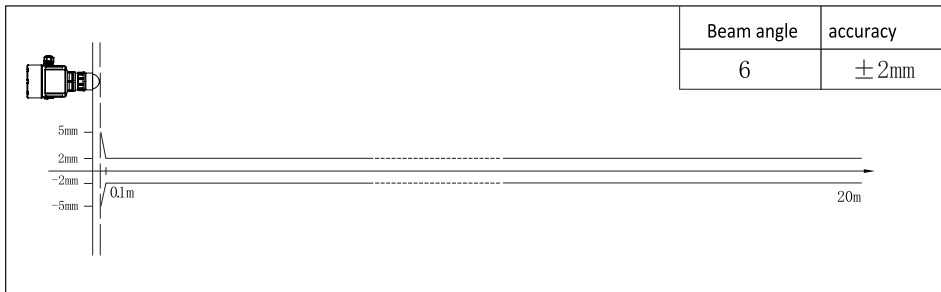
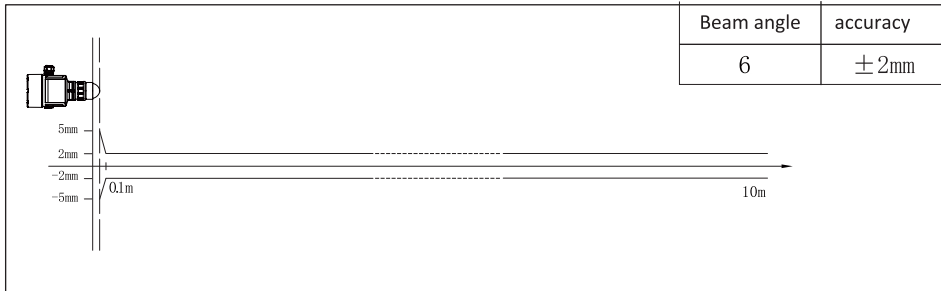

figure 16

7. Product Structure Dimensions (Unit: mm)



8 .Linear Graph



9.Transportation and Storage

In addition the transportation and storage conditions of level meter shall also meet the following requirements:

1. The material level meter shall be transported in strict accordance with the characteristics of the product and the requirements of the instructions.
2. The level meter shall be stored in a dry and ventilated room with a temperature of (- 20~60) °C and a relative humidity of no more than 80%. Do not mix with corrosive substances. Instruments that have been stored for a long time shall be sold and used after corresponding tests.



Address: 7191 Yonge street, Toronto, Canada

Tel: +16472221281(5 line)

Web: www.madecotech.com

Email: Info@madecotech.com