

# General Specifications

## FC800D, FLXA402T Non-reagent type Free Available Chlorine Analyzer

GS 12F05B10-01EN

### ■ General

Most of the countries have their safety regulation on free chlorine concentrations in tap water distribution. Monitoring free chlorine concentrations in distribution water is an important factor in water quality control.

Non-reagent type Free Available Chlorine Analyzer, composed of FC800D Non-reagent Type Chlorine Sensor Unit and FLXA402T Liquid Analyzer for Turbidity and Chlorine, is suitable for managing water purification, distribution, and free chlorine control in uses, being mainly used at measuring points in public facilities such as pumping stations, distribution stations, schools, and public halls on the water pipeline network in addition to the water treatment plant.

FC800D measures free chlorine by Amperometric principle. It employs a polarographic method by rotating electrode, which has been proven to be reliable in conventional models, to continuously measure the concentration of free chlorine on-line.

FLXA402T a next-generation analyzer is designed, being tailored from the well-received FLXA402 technical, to provide analysis with user-friendly color HMI that support multiple-input and digital communications.

The technology of predictive maintenance prevents accidental shutdown of the factory. These functions help to reduce OPEX. FC800D has drastically improved maintainability and minimized the maintenance time.

### ■ Features

#### FC800D

- Inherited the cleaning method with contamination-resistant rotating electrode and beads
- Improved maintainability
  - Easy clean up cell structure
  - Rotation mechanism with belt/slip ring without adjustment
  - Easy to find best condition by monitoring applied voltage and plateau characteristic

#### FLXA402T

- Diagnosis function
  - Motor rotation monitoring, empty cell detection, sensor condition check (zero point, Slope, stability during calibration)
- Output signal: Linear or polyline output (4-20 mA)
- Communications
  - Analog output, Digital communication (Modbus RTU or Modbus TCP/IP)
- Multiple detector/sensor connection
  - Chlorine (Non-reagent type), Turbidity, pH, Conductivity
- Multilingual display
  - English, German, French, Chinese, Korean, Spanish, Portuguese, Japanese



### ■ System Configuration

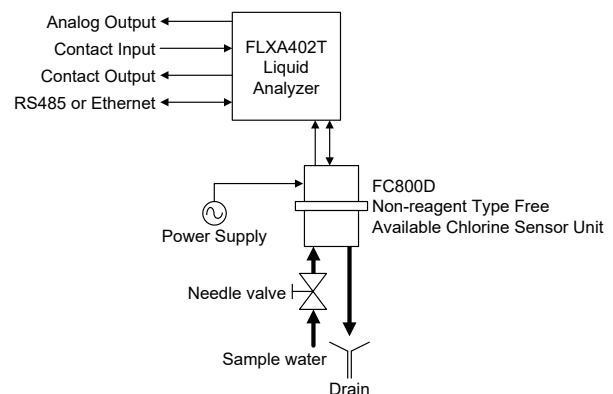

FLEXA, FLXA, SENCOM are trademarks or registered trademarks of Yokogawa Electric Corporation. All other company and product names mentioned in this document are trademarks or registered trademarks of their respective companies. We do not use TM or ® mark to indicate those trademarks or registered trademarks in this document.

## ■ System Configuration (multiple connection)

FLXA402T enables multiple sensor/detector connection for chlorine (Non-reagent type), turbidity, pH, conductivity. Select 2nd Input for multiple sensor/detector connection.

2nd Input	-CL	-TB		-P1	-C1
<b>Connectable sensor/detector (to be purchased separately)</b>	FC800D	TB820D	TB830D	FU20, FU24, SM21/SR20 PH20 SC25V SC21 SC29C PH8E□P PH4□ PH4□□	SC4A SC42 SX42 SC4AJ SC8SG SC210G
<b>Conditions</b>	FC800D-□□-A□-NN-NN (/ST cannot be selected.)	TB820D-□□-A□-□□-□□-CT-NN	TB830D-□□-A□-NN-□N-NN-NN-NN Select always "-NN" (Without sampling system) for the Sampling system.	Except for Variopin connector (-V) of PH8E□P	Except for Variopin connector (-VS) of SC4AJ, SC8SG. Except for Variopin connector (-□V) of SC42, SX42.

### </ST for sampling system>

- When /ST is specified on FC800D, select the code of System instruments -FC5, -PF7, or -PF8, for the ST401G which is to be ordered separately.
- ST401G can be equipped with only FC800D (-FC5) or FC800D and pH sensor together (-PF7, -PF8).
- When -PF8 on ST401G is specified, select -P1 for the second input.

**FLXA402T 2nd input "-TB"**

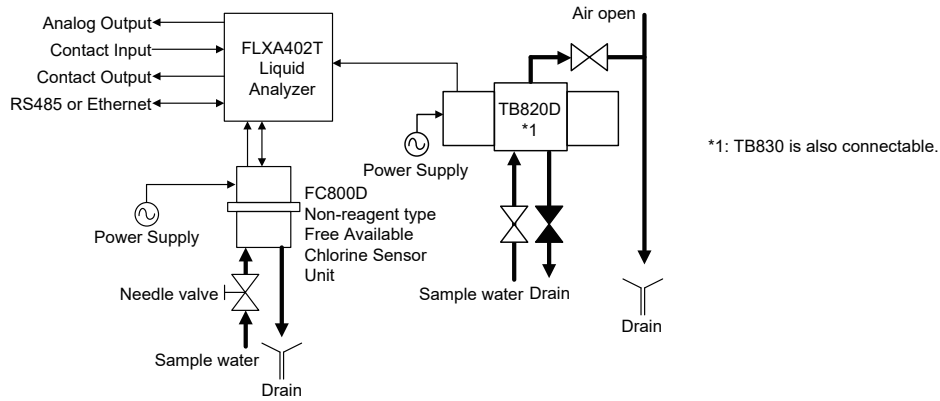

**FLXA402T 2nd input "-CL"**

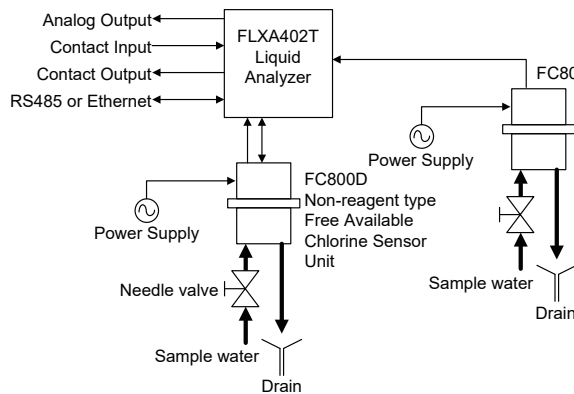

**FLXA402T 2nd input "-P1" or "-C1"**

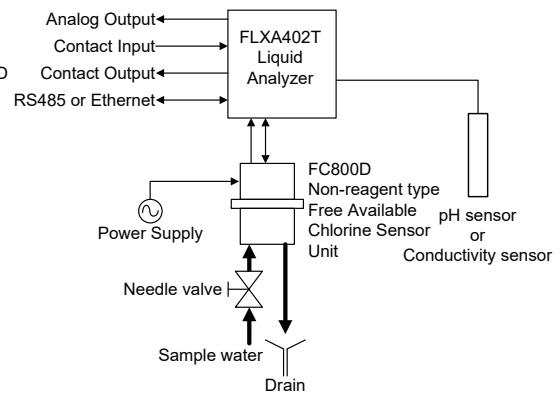

**To connect ST401G to FC800D and pH sensor**

Connect both FC800D and pH sensor to one FLXA402T  
(For FLXA402T 2nd input, select "-P1".)

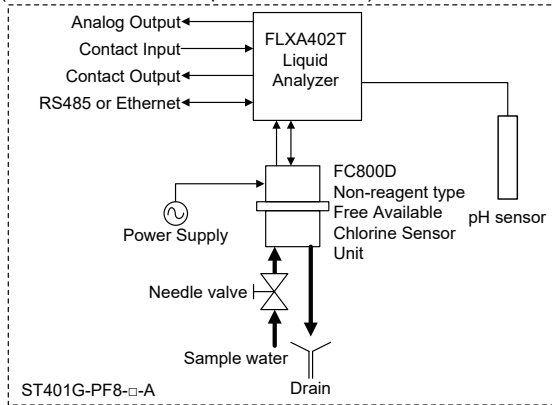

Connect FC800D and pH sensor separately to FLXA402T  
(For FLXA402T 2nd input, select "-NN", not "-P1".)

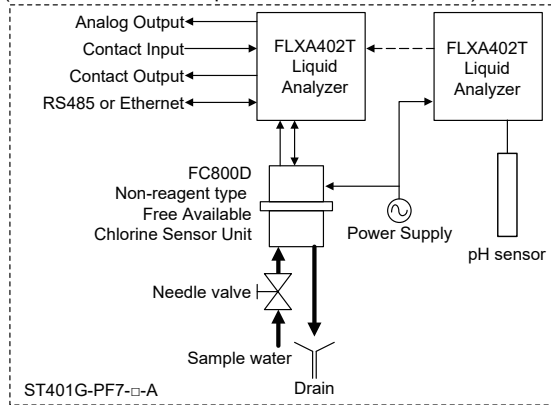

## ■ General Specifications

### 1. FC800D Non-reagent Type Free Available Chlorine Sensor Unit

#### ■ Measurement

Free chlorine concentration in water supply

Measuring method:

Amperometric (polarography) method

#### ■ Sensor for suffix code -F1 and -C1

Measuring range: 0-1 mg/L to 0-3mg/L

Linearity:

±5% of reading or ±0.05 mg/L whichever is greater

Repeatability:

±1% of reading or ±0.01 mg/L whichever is greater

Response time: Approx. 2 minutes (90% response)

Sample conditions:

Sample Temperature: 0 to 50°C (Temperature compensation is effective within 0 to 40°C)

Flow rate: 0.1 to 2.5 L/min

Pressure: 1 to 150 kPa

pH: Under the following conditions and no pH fluctuation

-F1

pH 6 to 8 (Chlorine value ≤1mg/L)

pH 6.5 to 7.5 (Chlorine value >1mg/L, ≤3mg/L)

-C1

pH 6.5 to 7.5

Conductivity: Under the following conditions and no fluctuation (\*1)

-F1

100 to 500 μS/cm (Chlorine value ≤1mg/L)

100 to 300 μS/cm (Chlorine value >1mg/L, ≤3mg/L)

-C1

100 to 300 μS/cm

(\*1) In case conductivity is over the upper limit, applied voltage needs to be changed.

SS: under 10mg/L

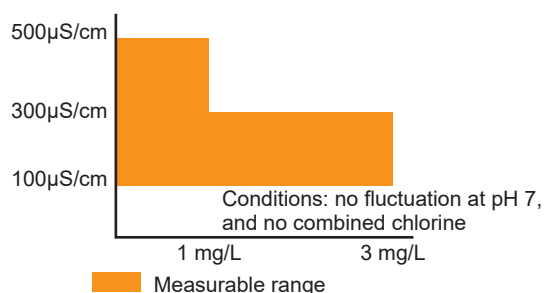
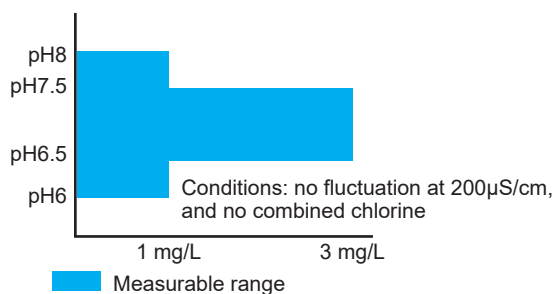

Electrode:

Measurement Electrode; Rotating gold electrode or rotating gold alloy electrode (in case combined chlorine insensitive electrode)

Reference electrode; AgCl Electrode with PT1000 temperature sensor

Auto electrode cleaning: Ceramic beads cleaning or Glass beads cleaning (For combined chlorine insensitive electrode)

Sensor error detection: Over diffusion current value, temperature error, applied voltage error, out of temperature compensation range, Zero calibration error, span calibration error, unstable calibration error, stopped motor rotation, empty cell.

pH compensation (only for -F1)

FLXA402T compensate pH with pH measurement module.

pH compensation is effective within pH 5-9

#### ■ Sensor for suffix code -F2 and -F3

Constant monitoring or alarm detection of free chlorine concentration (\*1) (\*2)

Repeatability:

-F2 ± 5% of full scale (5mg/L)

-F3 ± 5% of full scale (10mg/L)

Response time: approx. 2minutes (90% response)

Sample condition

Sample temperature: 0 to 40°C (Temperature compensation is effective within 5 to 35°C)

Flow rate: 0.1 to 2.5 L/min

Pressure: 1 to 150 kPa

pH: Under the following condition and no pH fluctuation  
pH6.5 to 7.5 (\*1)

Conductivity: Under the following conditions and no fluctuation  
over 200 μS/cm (\*1)

SS: under 10mg/L

(\*1): You may need to adjust applied voltage and provide a calibration by using a sample to use under the following conditions.

- Sample concentration is over 3 mg/L
- pH, conductivity value is out of the described range.

(\*2): If a calibration point is different from sample concentration, the sample condition is more likely to affect the result. Perform calibration with as close to the monitoring concentration as possible.

Electrode:

Measurement Electrode; Rotating gold electrode  
Reference electrode; AgCl Electrode with PT1000 temperature sensor

Auto electrode cleaning: Ceramic beads cleaning

Sensor error detection:

Over diffusion current value, temperature error, applied voltage error, out of temperature compensation range, Zero calibration error, span calibration error, unstable calibration error, stopped motor rotation, empty cell.

#### ■ Electrical

AC Power Supply

Ratings: 100 to 240 V AC

Acceptable range; 90 to 264 V AC

Ratings: 50/60 Hz

Acceptable range: 50 Hz ± 5 %, 60 Hz ± 5 %

Power consumption: 15VA (including Converter: max. 50VA)

Communication between Analyzer and Sensor unit:  
RS485 (Modbus RTU) 9600bps  
The maximum cable length between Analyzer and  
Sensor unit is 20 m  
The analyzer does not have data recording capabilities,  
but can be connected to an external data recorder.

#### ■ Mechanical and others

Case:

Color Black, Light silver gray (RAL 260 80 05)  
Finish; None

Material:

Smart unit: PC (poly carbonate) resin  
Electrode unit: m-PPE resin, SUS316

Wetted parts:

Flow cell: Acrylic resin  
Pipe: Polyethylene resin, Rigid polyvinyl chloride

Protection:

Smart unit IP65 NEMA Type4X (USA), CSA Type 4X (Canada)

Weight: Approx. 3.0 kg

Mounting:

Wall mounting(standard)  
Pipe mounting(option)  
Pipe mounting by Integrated mounting plate for  
analyzer and sensor unit (option)

Terminal screw size: M3 (Earth terminal: M4)

Cable gland: \* 5 holes, M20 Cable gland  
(For 6.5 to 12.5 mm outer diameter cable)

Note: Cable gland is installed at the factory.  
FC800D model

- Drain port (Ø15 hose joint)
- Sample inlet (Rc1/4)

Conduit adapter (option): G1/2, 1/2NPT or M20 × 1.5

Stainless steel tag plate (option): When you specify  
Option code /SCT, Tag plate on which the  
number is printed is shipped with product.  
You can attach this tag by wire.

Warm up time: Approx. 30 min

Installation/Storage environment:

Ambient Operating Temperature; -10 to 55°C  
(Please keep water flowing and avoid  
frozen up.)

Storage Temperature; -30 to 70°C

Humidity; 10 to 90 % RH at 40°C (No  
condensation)

Indoors (A separate rainproof cover is required for  
outdoor installation. Required a roof to  
avoid direct sunshine)

#### ■ Compliance method

Compliant with EPA Method 334.0 for Free Chlorine  
Measurement.

#### ■ Safety standard, EMC and RoHS

Safety:

EN 61010-1, EN IEC 61010-2-030  
UL 61010-1, UL 61010-2-030  
CSA C22.2 No.61010-1,  
CSA C22.2 No.61010-2-030 GB30439  
NM EN 61010 1, NM EN 61010 2 030

Installation altitude: 2000 m or less  
Overvoltage Category (IEC 61010): II (\*)

Pollution level (IEC 61010): 2 (\*\*)

- (\*) Installation category, called over-voltage category,  
specifies impulse withstand voltage.  
Equipment with Category II is energy-consuming  
equipment to be supplied from the fixed installation.
- (\*\*) Pollution level shows the level of existing the solid,  
liquid and gas which break electrical isolation.  
Category 2 is applied to normal room environment.

EMC:

EN 61326-1 Class A, Table 2 (For use in industrial locations)  
EN 61326-2-3  
EN 61000-3-2  
EN IEC 61000-3-2  
EN 61000-3-3  
RCM: EN 55011 Class A, Group 1  
Korea Electromagnetic Conformity Standard

한국 전자파적합성 기준 Class A

NM EN 61326 1, NM EN 61326 2 3  
NM EN 61000 3 2, NM EN 61000 3 3

Environmental regulation:

RoHS: EN IEC 63000

Information of the WEEE Directive

This product is purposely designed to be used in a  
large scale fixed installations only and, therefore,  
is out of scope of the WEEE Directive. The WEEE  
Directive does not apply.

The WEEE Directive is only valid in the EU.

## 2. Liquid Analyzer FLXA402T

Liquid Analyzer FLXA402T is common converter for  
Chlorine sensor unit and Turbidity detector. In this  
GS, only function and specification are provided for  
the connection between FLXA402T and FC800D.

### 2-1 Measurement

#### ■ SENCOM for Chlorine

Unit: mg/L, ppm, You can input any letters by  
alphanumeric.

Display resolution: 0.000 to 9999

Regarding specification of detector, refer to 1.FC800D Non-  
reagent Type Free Available Chlorine Sensor Unit

#### ■ pH (PH)

When 2nd Input is -P1 (PH)

Input Specification

Dual high impedance input ( $\geq 10^{12} \Omega$ )

Input Range

pH: -2 to 16 pH

Temperature:

Pt1000: -30 to 140 °C

Pt100: -30 to 140 °C

6k8: -30 to 140 °C

PTC10k: -30 to 140 °C

NTC 8k55: -10 to 120 °C

3k Balco: -30 to 140 °C

PTC500: -30 to 140 °C

Output Range

pH: min. span 1 pH  
max. span 20 pH

Performance (Accuracy)

(The specifications are expressed with simulated inputs.)  
pH

Linearity:  $\pm 0.01$  pH

Repeatability:  $\pm 0.01$  pH

Accuracy  $\pm 0.01$  pH

Temperature

with Pt1000, 6k8, PTC10k, NTC 8k55, 3k Balco,  
PTC500

Linearity:  $\pm 0.3$  °C

Repeatability:  $\pm 0.1$  °C

Accuracy:  $\pm 0.3$  °C

with Pt100

Linearity:  $\pm 0.4$  °C

Repeatability:  $\pm 0.1$  °C

Accuracy:  $\pm 0.4$  °C

### Temperature compensation

Function:

Automatic or manual. Compensation to Nernst equation. Process compensation by configurable temperature coefficient.

### Calibration

Semi-automatic 1 or 2 point calibration using pre-configured NIST, US, DIN buffer tables 4, 7 & 9, Manual adjustment with automatic stability check.

### ■ Conductivity (SC)

#### When 2nd Input is -C1 (SC)

#### Input Specification

Two or four electrodes measurement with square wave excitation, using max 60m (200 ft) cable (WU40/WF10) and cell constants from 0.005 to 50.0 cm<sup>-1</sup>

#### Input Range

Conductivity:

min.: 0 μS/cm  
max.: 200 mS x (Cell constant)  
(over range 2000 mS/cm)

Temperature:

Pt1000: -20 to 250 °C  
Pt100: -20 to 200 °C  
Ni100: -20 to 200 °C  
NTC 8k55: -10 to 120 °C  
Pb36(JIS NTC 6k): -20 to 120 °C

#### Output Range

Conductivity:

min. 0.01 μS/cm  
max. 2000 mS/cm (max 90% zero suppression)

Temperature:

min. span 25 °C  
max. span 270 °C

#### Performance (Accuracy)

(The specifications are expressed with simulated inputs.)

Conductivity

2 μS x K cm<sup>-1</sup> to 200 mS x K cm<sup>-1</sup>

Accuracy: ±0.5%F.S.

1 μS x K cm<sup>-1</sup> to 2 μS x K cm<sup>-1</sup>

Accuracy: ±1%F.S.

Temperature

with Pt1000, Pb36, Ni100

Accuracy: ±0.3 °C

with Pt100, NTC 8k55

Accuracy: ±0.4 °C

Temperature compensation

NaCl table: ±1 %

Step response: 90 % (< 2 decades) in 7 seconds

Note: "F.S." means maximum setting value of converter output.

"K" means cell constant.

YOKOGAWA provides conductivity sensors of whose cell constants are 0.1 to 10 cm<sup>-1</sup>.

## 2-2. Electrical

### ■ Display

Display: QVGA color LCD with a touch screen

Message Language: English, German, French, Chinese, Korean, Spanish, Portuguese, Japanese

Note: You may find some image loss, uneven brightness, or afterimage on display. They are generated from the product features but not defects.

### ■ AC Power supply;

Ratings: 100 to 240 V AC

Acceptable range: 90 to 264 V AC

Ratings: 50/60 Hz

Acceptable range: 50 Hz ± 5 %, 60 Hz ± 5%

Power Consumption: 35 VA

### ■ Output signal:

Isolated outputs: 4-20 mA DC

Accuracy: ± 0.02 mA

Repeatability: ± 0.02 mA

Linearity: ± 0.02 mA

Maximum load: 600 Ω

Number of outputs: select by suffix code

2 isolated outputs: -N2

4 isolated outputs: -N4

(Not isolated between analog outputs 1 and 2)

Output range: Configure within measurement range

Minimum range: minimum measurement range

Maximum range: maximum measurement range

Minimum span: 1 mg/L or more

(\*) In case auto range switching function is enable, low range is fixed by 0 mg/L.

Automatic range switching function:

Ch1: No switching or switching in 2 or 3 points

You can select the followings.

"Manual range switching, Remote range switching, Automatic 2 range switching, Automatic 3 range switching"

Ch2-Ch4: No switching or 2 range switching

You can select the followings.

"Manual switching, Remote 2 range switching"

Output function: Linear or polyline output ( If

you specify one point current output

% value and one point process value

between upper and lower limit values, they are linearly interpolated and output, respectively)

Output current; 2.4 to 21.6 mA

Output signal during maintenance (HOLD): Enable/ Disable keep output value function during setting, calibration and maintenance (Automatic hold function).

You can set HOLD value the last value or any value between 2.2 mA to 22.0 mA

Burn out function (NAMUR 43)

Analyzer can output 2.2 mA (Burn down) or to alarm failure.

Burn down: 2.2 mA

Burn up: 22.0 mA

### ■ Contact outputs

#### When -WR is selected.

Type: No-voltage contact output

Number: 4 contacts (S1/S2/S3/S4)

Contact S4 is for Fail-safe function.

Function: Selectable 4 functions among Alarm, maintenance mode, wash, wash/ calibration status, mA1 output range status.

Wash contact: Auto wash contact for Non-reagent type free chlorine sensor unit or Solenoid valve operation contact for Auto calibration (Only S3 is possible to specify.)

#### Identification of range switching:

Contacts (S1/S2/S3) identifies mA output range. Up to 3 contacts are used for 3 ranges. Refer to User's manual when using 2 contacts to identify 3 ranges.

#### Switch capacity:

Maximum values; 100 VA, 250 V AC, 5A (\*)

Maximum values; 50 W, 24 V DC, 5A (\*)

(\*): This specification is in case of "-N2". In case of "-N4", maximum switch current capacity is 4 A.

#### ■ Contact input;

Type; Non-voltage contact output  
 Number; 2 contacts (-N4), 1 contact (-N2)  
 Function; Select among Remote 2range switching, Remote 3range switching, Remote wash start, Remote calibration start, Disable

#### Remote range switching:

By contact input, mA output is switched to range "2" or range "3". Range "3" is available only to mA1.

Short-circuit resistance (on resistance); maximum 200 Ω  
 Open resistance (off resistance); minimum 100k Ω

#### ■ Digital communication (option):

Ethernet (Modbus TCP): 10/100 Mbps  
 Cable length: maximum 100 m  
 RS-485 (Modbus RTU): 115200/38400/9600 bps  
 Cable length:  
 115200 bps: maximum 600m  
 38400 bps, 9600 bps: maximum 1200m

#### ■ Analog Input (mA, O/I code: -N4)

Temperature compensation (pH, SC, Chlorine)  
 pH compensation for FC800D-F1  
 Isolated Input: 4 to 20 mA DC  
 Accuracy: ± 0.02 mA  
 Number: 1

#### ■ Calibration, wash, diagnosis and other functions

Calibration function:  
 Zero calibration: Empty cell Zero calibration, Circuit noise adjustment, Zero Calibration by zero chlorine solution.  
 Slope calibration: Sample or solution

Automatic calibration function:  
 Automatic Zero Calibration\* (by Activated charcoal filtered water)

pH Compensation function: Only for FC800D-F1  
 pH compensation is effective within pH5 to 9

Automatic wash/Automatic calibration function:  
 Selectable when /ST (option) on FC800D and /AZC□ on ST401G are specified.  
 Or need to select /TB (option) and prepare a sampling system with activated charcoal filter.

Automatic wash function  
 Wash cell by tap water\*  
 \* Required calibration/wash controller and solenoid valve.

Automatic calibration function  
 Auto-zero calibration with activated charcoal-filtered water (free-chlorine water)

Display maintenance information: Operating time management (Replacement date of rotating contact, Measurement electrode operating time, Beads operating time, Motor operating time, Coupling operating time, Shaft assy operating time)

#### 2-3. Mechanical and others

Housing: Aluminum alloy cast  
 Case  
 Color; Silver gray  
 Finish; Chemical resistant coating or high anti-corrosion coating  
 Window: Polycarbonate  
 Protection: IP66 NEMA Type 4X (USA), CSA Type 4X (Canada)  
 Please add Hood option (/H□) in case of using outdoor  
 Size: 165×165×168.5 mm (W×H×D)  
 Not included cable gland  
 Weight: Maximum 1.5 kg  
 Mounting hardware (option):  
 -Pipe and wall mounting hardware  
 -Panel mounting hardware  
 Hood (option):  
 -Stainless steel  
 -Stainless steel with chemically resistant coating  
 Terminal screw size; M3 (Earth terminal: M4)  
 Cable gland: 8 holes, M20 Cable gland x 8  
 (For 6 to 12 mm outer diameter cable)  
 Note; Please screw up them by yourself  
 Conduit adopter (option):  
 G1/2, 1/2 NPT or M20 × 1.5  
 Note: Please order required numbers.  
 Stainless Steel Tag Plate (option): In case you specified Option code /SCT, Tag plate on which is the number is printed is shipped with product. You can attach this tag by wire.

Warm up time: Approx. 30 min  
 Installation/Storage environment:  
 Ambient Operating Temperature; -20 to 55°C  
 Storage Temperature; -30 to 70°C  
 Humidity; 10 to 90 % RH at 40°C  
 (No condensation)

#### 2-4 Safety standard, EMC and RoHS

Safety:  
 EN 61010-1, EN IEC 61010-2-030  
 UL 61010-1, UL 61010-2-030  
 CSA C22.2 No.61010-1,  
 CSA C22.2 No.61010-2-030  
 GB30439  
 Installation altitude: 2000 m or less  
 Overvoltage Category (IEC 61010): II (\*)  
 Pollution level (IEC 61010): 2 (\*\*)  
 (\*): Installation category, called over-voltage category, specifies impulse withstand voltage.  
 Equipment with Category II is energy-consuming equipment to be supplied from the fixed installation.  
 (\*\*): Pollution level shows the level of existing the solid, liquid and gas which break electrical isolation.  
 Category 2 is applied to normal room environment.

EMC:  
 EN 61326-1 Class A, Table 2 (For use in industrial locations)  
 EN 61326-2-3  
 EN 61000-3-2  
 EN IEC 61000-3-2  
 EN 61000-3-3  
 RCM: EN 55011 Class A, Group 1  
 Korea Electromagnetic Conformity Standard

한국 전자파적합성 기준 Class A

Environmental regulation:  
 RoHS: EN IEC 63000

---

#### Information of the WEEE Directive

This product is purposely designed to be used in a large scale fixed installations only and, therefore, is out of scope of the WEEE Directive. The WEEE Directive does not apply.

The WEEE Directive is only valid in the EU.

### **3. Sampling system**

ST401G combined with FC800D builds a sampling system. When the sample pressure or/and the sample flow rate is high, use ST401G. Refer to GS 12A00V02-01E.



## ■ Model & Suffix Codes

### FC800D Non-reagent Type Free Available Chlorine Sensor Unit

Model	Suffix code	Option code	Description
FC800D	.....	.....	Non-reagent Type Free Available Chlorine Sensor Unit
Measurement object and Range	-F1	.....	Free chlorine 0-1 to 0-3 mg/L
	-C1	.....	Combined chlorine insensitive version 0-1 to 0-3 mg/L
	-F2	.....	Free chlorine 0-5 mg/L
	-F3	.....	Free chlorine 0-10 mg/L
Type	-AB	.....	General purpose for CE, RCM, China standard
	-AD	.....	General purpose for CSA
	-AG	.....	General purpose for KC
	-AJ	.....	General purpose
—	-NN	.....	Always -NN
—	-NN	.....	Always -NN
Option	/L02		Connection cable for analyzer 2 m (*1)
	/L03		Connection cable for analyzer 3 m (*1)
	/L05		Connection cable for analyzer 5 m (*1)
	/L10		Connection cable for analyzer 10 m (*1)
	/L20		Connection cable for analyzer 20 m (*1)
	/SCT		Stainless steel tag plate
	/U		Pipe mounting hardware (SUS) (*4)
	/V		Integrated mounting plate for analyzer and sensor unit (*2) (*4)
	/CB3		Conduit adapter G1/2× 3 pcs (*5) (*6)
	/CD3		Conduit adapter 1/2NPT × 3 pcs (*5) (*6)
	/CF3		Conduit adapter M20 × 1.5 × 3 pcs (*5) (*6)
/TB		Terminal Box for connecting automatic wash/cal. valve (*3) (*6)	
/ST		Assembled in stanchion (*7)	

\*1: 1 m cable is included in the product. Select this code for other cable length to use.

\*2: Integrated pipe mounting is possible between the analyzer and sensor unit. Use 1 m cable included in the product. If FC400G is replaced with FC800D, the integrated mounting plate for FC400G can be used continuously without replace. Mounting hardware for FLXA402T cannot be used for this integrated plate. See ● Mounting Hardware (Option).

\*3: In order to perform automatic wash/calibration without "/ST" Option, be sure to specify "/TB". Option "/L□□" is not selectable. Terminal Box is wall mounted.

You need to purchase separately solenoid valve, activated charcoal filter for zero calibration, and cables.

Terminal Box for connecting automatic wash/cal. valve, 1 m cable for converter-Terminal Box, 1 m cable for sensor-Terminal Box (K8004RA) are included in the product.

Regarding recommended solenoid valve, refer to Piping. See ● Solenoid valve (SV1).

\*4: Wall mounting is available to standard model. See ● Mounting Hardware (Option).

\*5 See ● Required Number of Conduit Adapters. After completing conduit work on FC800D, you can use the unused conduit adapters for the conduit of FLXA402T. However, when "-AD" is selected, always specify FC800D Option "/C□3".

When "/TB" is selected, connect a power supply cable to Terminal box. In other cases, connect the power cable to Smart Unit.

\*6 When "-AD" (CSA) is selected with both "/TB" and "/C□3", a plate for Terminal Box comes with the product. You must install the plate on Terminal Box when you attach conduit adapters. See ● Required number of conduit adapters.

\*7 Be sure to specify "/ST" only when the FC800D is shipped attached to the ST401G dedicated sampling system. For other cases, do not select "/ST". (If you want to attach FC800D to the ST401G that you are currently using, you cannot select "/ST".) It can be specified only when "-AJ" is selected. Use the 1m cable (included in the product). Option "/L□□", "/U", "/V", "/C□3" cannot be selected. Be sure to specify "-ST" (Assembled in stanchion) and "-WR" (Contact outputs) as the suffix code for FLXA402T.

Do not select "/ST" when a FC800D is used for "-CL" of FLXA402T 2nd input. Only one FC800D can connect to one ST401G.

#### ● Accessories

Name	Q' ty	Remarks
Polishing powder (Alumina)	1 Bottle	For polishing measurement electrode (K9088PE)
Beads	1	2 bags / 1 Q' ty (-F□: K9332ZP, -C1: K9332ZJ)
Allen wrench	1	Nominal size : 2 mm
Rubber plug	2	Hole plugs for electrode unit

## ● Spare Parts

Name	Part No.	Description	Frequency of Replacement
Measurement Electrode (rotating electrode)	K8005JB	Gold electrode (-F□)	Yearly
Measurement Electrode (rotating electrode)	K8005JC	Gold alloy electrode, for Combined chlorine insensitive type (-C1)	Yearly
Reference Electrode	K8005UC	Silver/Silver chloride electrode	when damaged
Ceramic Beads	K9332ZP	For cleaning general type reference electrode. 2 bags/1 Q'ty	Yearly
Glass Beads	K9332ZJ	For combined chlorine intensive type (-C1), 2 packs/pcs	Yearly
Rotating Contact	K9332SR	Part for the electrode unit	Yearly
Driven Shaft Assembly	K8005LB	Part for the electrode unit	3 years
O-Ring	Y9115XB	Part for the electrode unit	3 years
Motor	K8005LC	Part for the electrode unit	3 years
Coupling	B1005AC	Part for the electrode unit	3 years
Activated Charcoal Filter	L9862AY	For zero calibration	Yearly
Fuse	A1633EF	250 V/2.5 A for the smart unit	(*1)
Fuse	A1624EF	250 V/3.15 A for the terminal box (/TB option)	(*1)

(\*1) Recommended replacement interval is for preventive maintenance, although parts may be used longer than those period described.

## ● Parts for Terminal Box for connecting automatic wash/calibration valve (/TB)

Terminal Box for connecting automatic wash/cal. valve, 1 m cable for converter-Terminal Box, 1 m cable for sensor-Terminal Box (K8004RA) are included in the product.

## ● Mounting Hardware (Option)

Select each corresponding hardware based on the table below.

Model	Mounting type			
	Integrated **	Wall	Pipe	Panel
FC800D	/V (Integrated)	Unselected (standard)	/U (Pipe mounting)	NA
FLXA402T	Unselected (standard)	/UM* or /U	/UM* or /U	/UM* or /PM

(Note) When "/ST" is selected on the FC800D, no mounting hardware is available to FLXA402T.

\*: Universal mounting kit (/UM) contains pipe, wall mounting hardware (/U) and panel mounting hardware (/PM).

\*\* : For an integrated mounting type, no mounting hardware is available to FLXA402T.

## ● Required Number of Conduit Adapters

If you need to perform conduit work on cables, specify the conduit adapter by Option code.

Conduit adapters and dedicated cable glands, which are used in place of the standard cable gland for cable entry holes, are supplied with the product.

You can specify the conduit adapter by Option code for both FC800D and FLXA402T.

But when "/ST" is selected on FC800D, no conduit adapter can be attached.

Be aware of the following.

- When FLXA402T Digital communication "-E" (Modbus TCP/IP) is selected  
If you attach a conduit adapter on the Modbus TCP/IP (Ethernet) cable entry, you need an Ethernet dedicated conduit adapter. Be sure to specify FLXA402T "/C□6".
- When Type of FC800D, FLXA402T is "-AD" (for CSA)  
Order a plate described below to install a conduit adapter for "-AD", otherwise the CSA safety standards will not be satisfied.  
For "-AD" (for CSA), specify FC800D "/C□3" on FC800D side.  
If "/C□3" is selected, FC800D is shipped equipped with the plate to FC800D smart unit.  
When "-AD" (CSA) is selected with both "/TB" and "/C□3", a plate for Terminal Box comes with the product.  
You must install the plate on Terminal Box when you attach conduit adapters.

Next diagram shows the position of each cable entry (●●) where you can attach conduit adapters for the conduit.

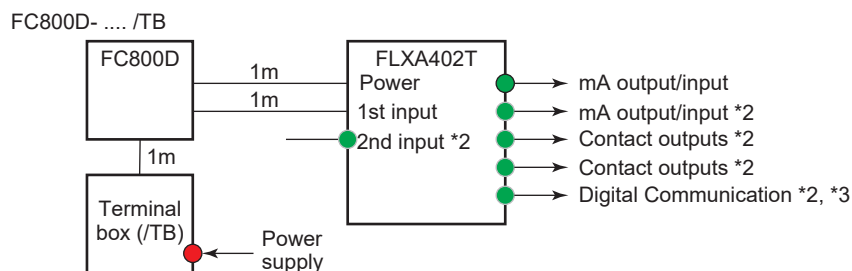
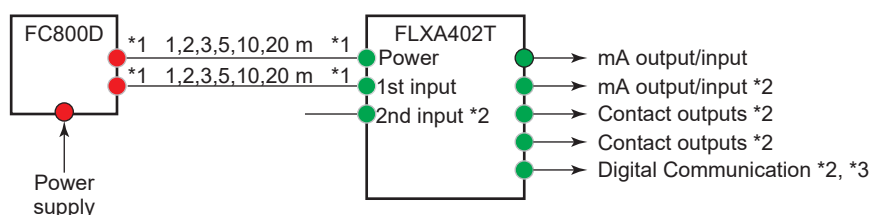

\*1: The standard cable length between FLXA402T and FC800D is 1 m. You can change the cable length by specifying a code from Option code.

\*2: The number of cable entry holes to be used are defined by the specification as below.

Spec. Code	2nd Input		mA output/input		Contact Outputs		Digital Communication		
	-NN	the others	-N2	-N4	-WR	-NR	-N	-E	-R
Required No. of cable entry holes	0	1	1	2	2	0	0	1*	1

\*: Conduit exclusively for Ethernet

\*3: For Ethernet cable, use Ethernet dedicated conduit adapter.

If you need more conduit adapters to meet the requirement, purchase additionally. See the table below.

#### Conduit adapter (for additional purchase)

Type	Parts number	Quantity	Remark
G 1/2 (Cable gland for adapter + adapter)	K9703WF	4 set	for Option code /CB□
1/2 NPT (Cable gland for adapter + adapter)	K9703WG	4 set	for Option code /CD□
M 20 x 1.5 (Cable gland for adapter + adapter)	K9703WH	4 set	for Option code /CF□

#### ● Solenoid valve (SV1)

##### SV1: 3-port solenoid valve

Requirement for sampling system

	Port size	Max. working pressure	Max. Working pressure differential
SV1	Rc 1/4	≥ 1.5 MPa	≥ 1.0 MPa

Example

		Voltage	100 V	200 V	220 V
SV1	Part number		B1007ET	B1009ET	B1010ET
	Model code		AG41-02-1-E2G-AC100V-S	AG41-02-1-E2GS-AC200V-ST	AG41-02-1-E2GS-AC220V-ST
	Manufacturer		CKD Corporation		

Recommended cable for solenoid valve

Part number	K8004RS
Cable length	1.2 m
Rated voltage	300 V
Specification	AWG20 2-core cable, M3 round terminal

## FLXA402T Liquid Analyzer for Turbidity and Chlorine

Liquid Analyzer FLXA402T is a common analyzer for Turbidity detector and Chlorine sensor unit. The table below for Model and Suffix Code (MS code) applies the combination between FLXA402T and FC800D.

Model	Suffix code	Option code	Description
FLXA402T			Liquid Analyzer for Turbidity and Chlorine
Power supply	-A		AC version
Housing (*1)	-B -D		Aluminum alloy cast + urethane coating Aluminum alloy cast + high anti-corrosion coating
Type (*2)	-AB -AD -AG -AJ		General purpose for CE, RCM, China standard General purpose for CSA General purpose for KC General purpose
1st Input	-CL		SENCOM for Chlorine
2nd Input (*3)	-NN -P1 -C1 -CL -TB		Without Input pH (*4) Conductivity (SC) SENCOM for Chlorine SENCOM for Turbidity (*5)
mA Output/Input	-N2 -N4		2 x 4-20 mA Output + 1 x Contact Input (without Hart) 4 x 4-20 mA Output + 2 x Contact Input + 1 x 4-20 mA Input (without HART)
Contact Outputs	-WR -NR		Contact outputs (Wash and Fail contact outputs) (*11) Without Contact outputs (without Wash and Fail contact outputs)
—	-N		Always -N
Digital Communication	-N -E -R		Without Digital communication Modbus TCP/IP Modbus RTU (RS-485)
Country (*6)	-N -J		Global except Japan Japan
Assembled in stanchion	-NN -ST		Not assembled in stanchion Assembled in stanchion (*11)
—	-NN		Always -NN
Option	Mounting hardware (*7) Hood Tag plate Conduit adapter (*9)	/UM /U /PM /H6 /H7 /SCT /CB4 /CD4 /CF4 /CB6 /CD6 /CF6	Universal mounting kit (*8) Pipe and wall mounting hardware Panel mounting hardware Hood, stainless steel Hood, stainless steel + urethane coating Stainless steel tag plate G1/2 x 4 pcs 1/2NPT x 4 pcs M20 x 1.5 x 4 pcs G1/2 x 3 pcs + G 1/2 for Ethernet x 1 pcs (*10) 1/2NPT x 3 pcs + 1/2 NPT for Ethernet x 1 pcs (*10) M20 x 1.5 x 3 pcs + M20 for Ethernet x 1 pcs (*10)

\*1: Urethane coating is acid resistant. Heavy duty coating is acid/alkali resistant.

\*2: Select same code as sensor's.

\*3: To detectors connected to 2nd Input, none of the following is available: auto washing, auto zero calibration, wiper cleaning.

\*4: Available for pH compensation of FC800D

\*5: SENCOM Turbidity is for TB820D (GS 12E01B30-01EN) or TB830D (GS 12E04B40-01EN).

\*6: Select only "-J" if you use the converter in Japan. Only SI unit (International System of Units) applies.

\*7: See ● Required Number of Conduit Adapters.

\*8: Universal mounting kit contains pipe, wall mounting hardware (/U) and panel mounting hardware (/PM).

\*9: See ● Mounting Hardware (Option).

\*10: Available only when "-E" (Modbus TCP/IP) to Digital communication is selected.

\*11: When "/ST" (Assembled in stanchion) is selected for FC800D, be sure to specify "-ST" (Assembled in stanchion) and "-WR" (Contact outputs) as the suffix code for FLXA402T. When "-ST" is specified, neither Mounting hardware (/UM, /U, /PM) nor Hood (/H6, /H7) can be selected.

For 2nd Input, "-C1" (Conductivity (SC)), "-CL" (SENCOM for Chlorine), "-TB" (SENCOM for Turbidity) are not selectable.

### ■ Optional parts

Name	Parts number	Quantity	Remark	
Mounting hardware	for pipe, wall mounting (stainless)	K9703SS	1 set	same as Option code /U
	for panel mounting (stainless)	K9703ZD	1 set	same as Option code /PM
Sun shade	Stainless	K9698WK	1 set	same as Option code /H6
hood	stainless + urethane	K9698WL	1 set	same as Option code /H7
Rubber plug attachment		K9334CN	1 pcs	for Cable gland
Fuse		A1633EF	1 pcs	250V/2.5A (minimum 5 pcs)

SD card	A1019NL	1 pcs	2 GB industrial SD card Customers can provide the cards with spec: Storage capacity: 128 MB or greater Type: SD, SDHC (with power failure recovery)
---------	---------	-------	--

## ■ Dimensions

### ● FC800D Non-reagent Type Free Available Chlorine Sensor Unit

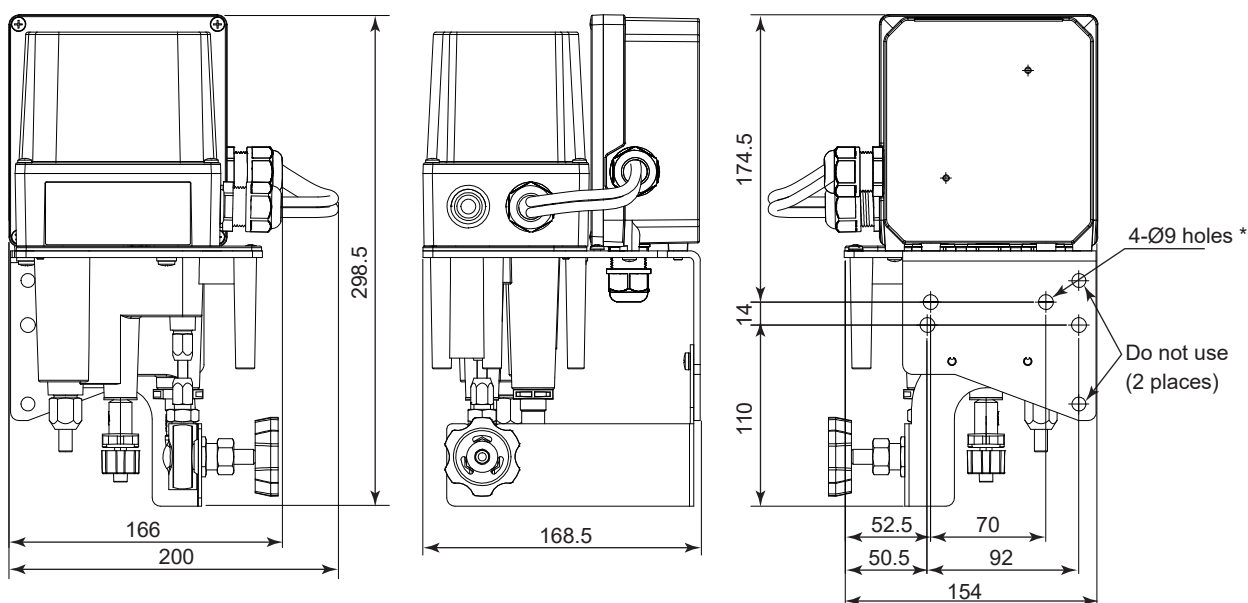
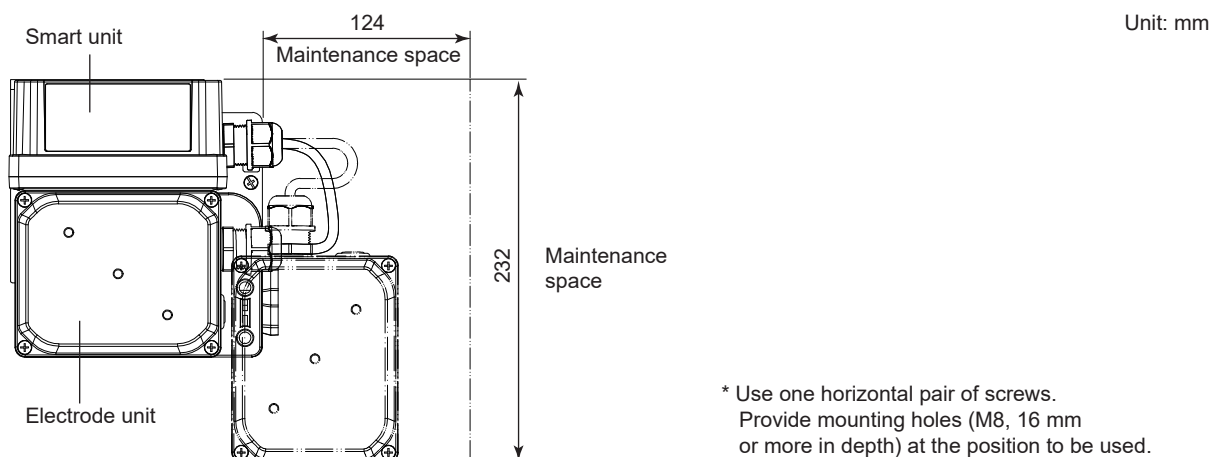

Note: For wall mounting, the wall should be strong enough to bear the weight of 15 kg or more.

**Conduit adaptor (/CB3, /CD3, /CF3)**

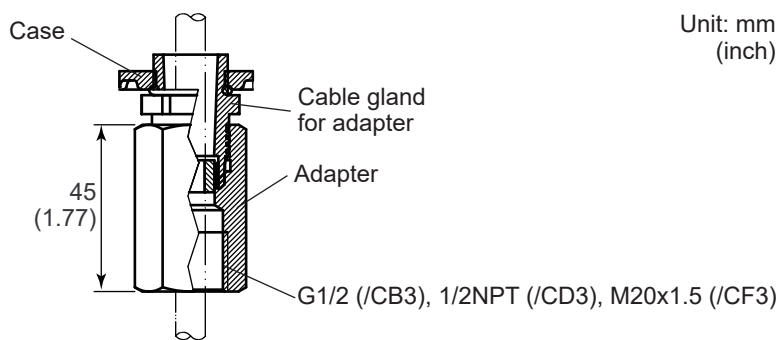

**Pipe mounting hardware (/U)**

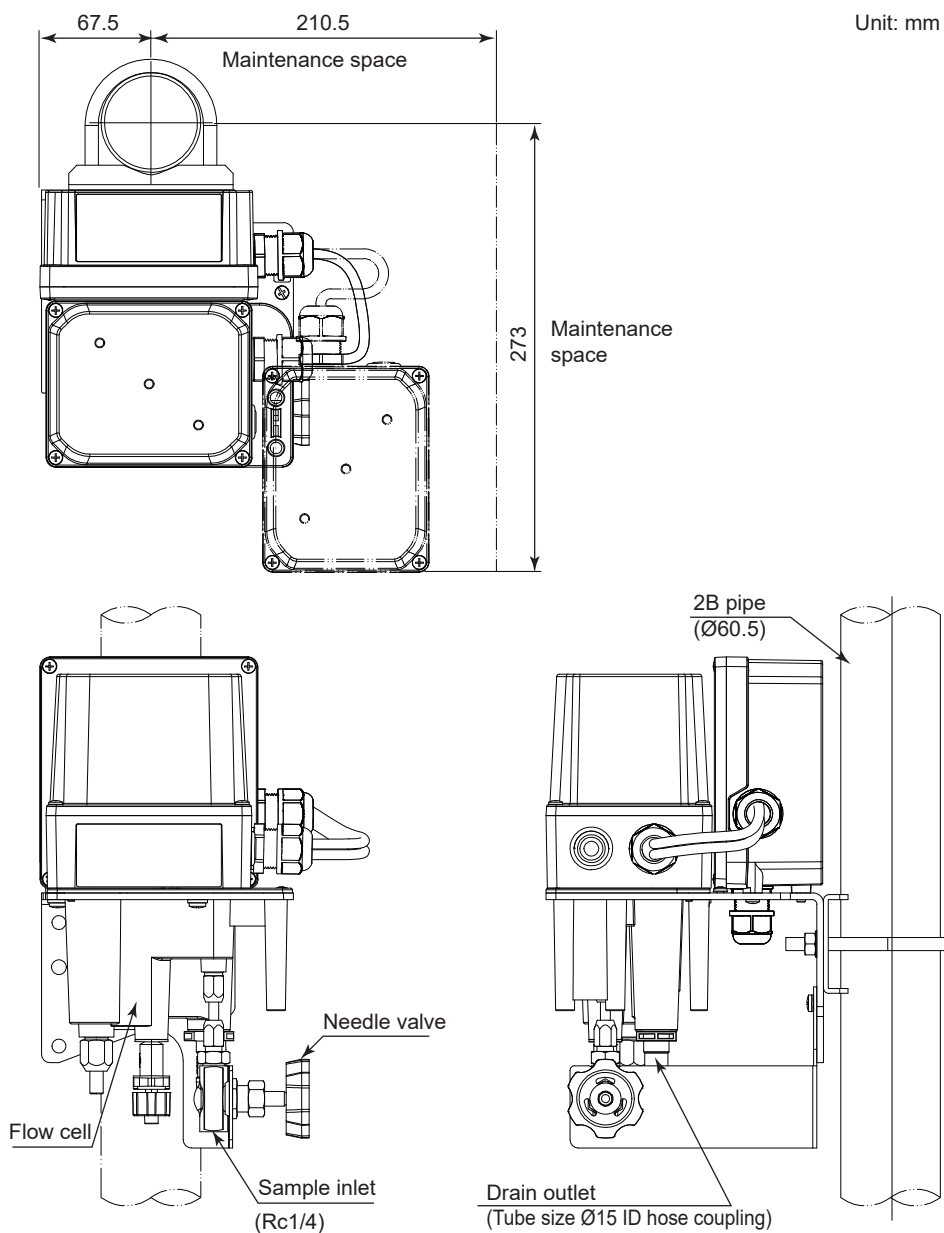

Mounting plate for integral mounting of FLXA402T and FC800D (IV)

Unit: mm

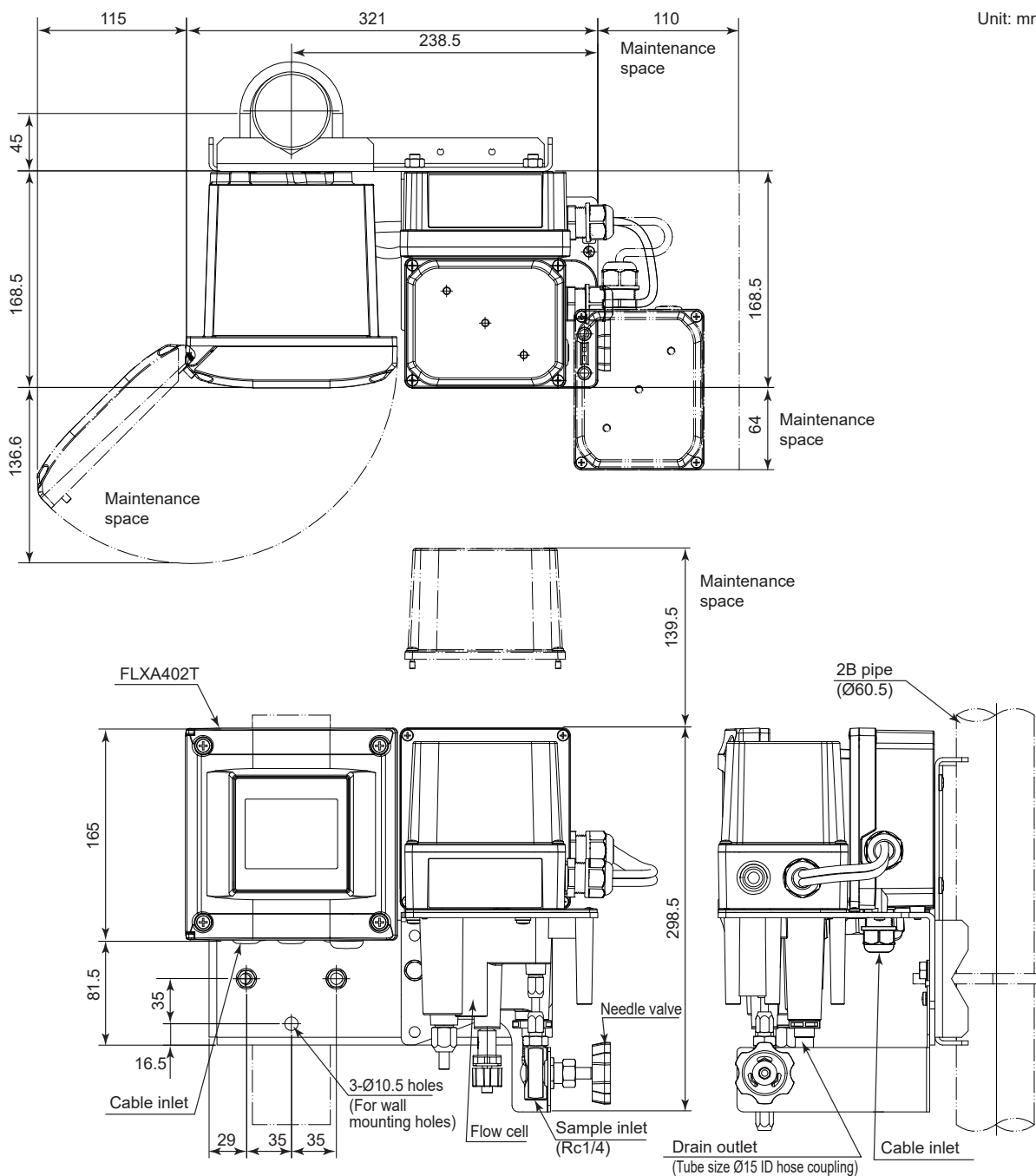

## Terminal Box (included for FC800D /TB)

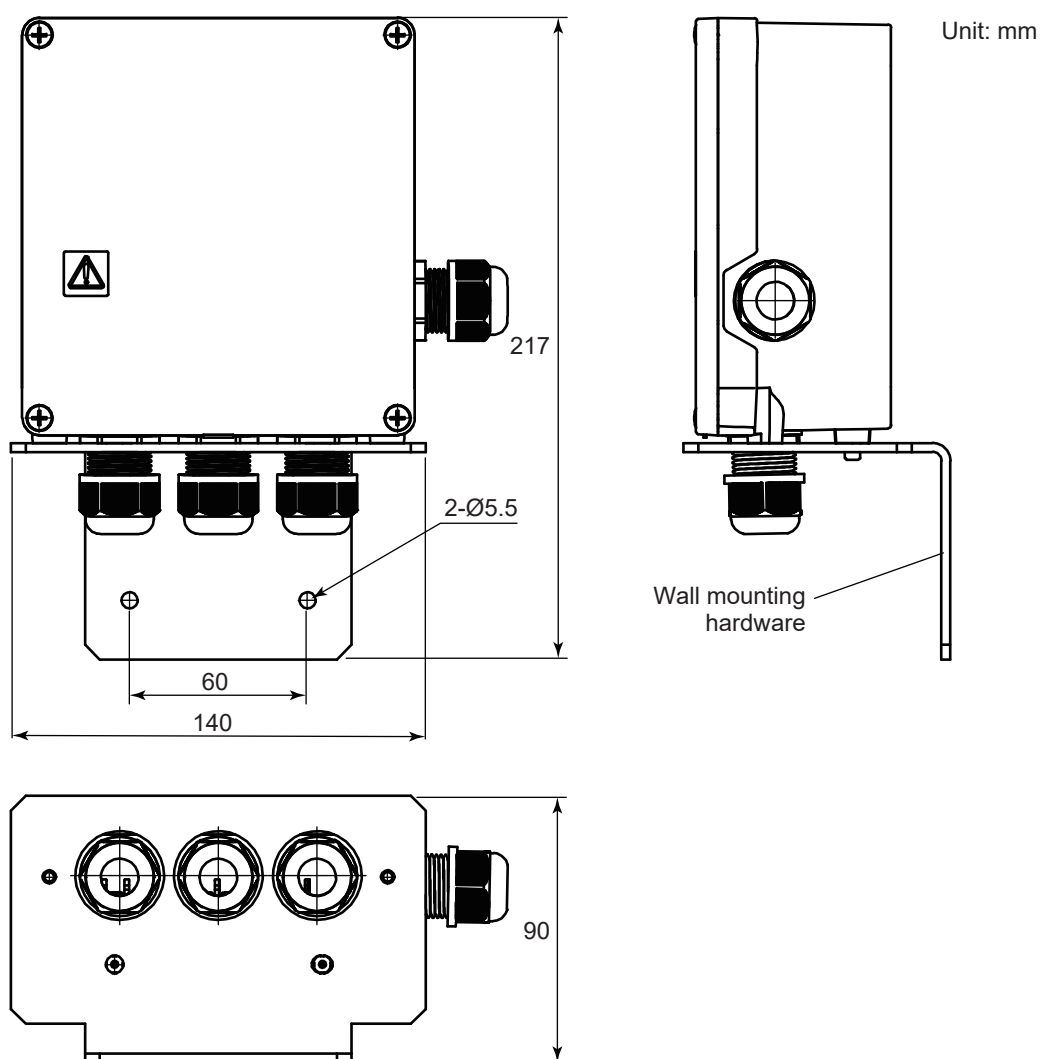



● FLXA402T Liquid Analyzer for Turbidity and Chlorine

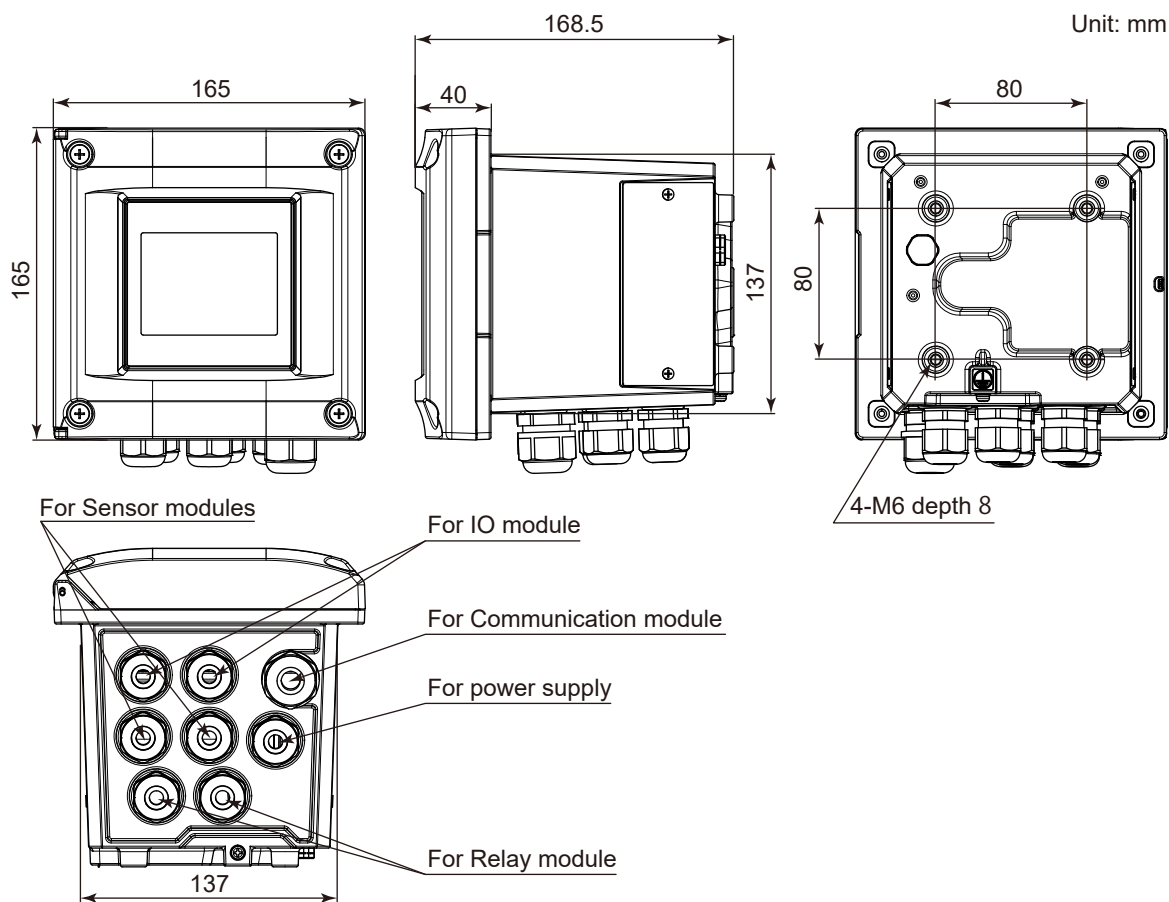

Conduit adaptor (/CB4, /CD4, /CF4/, /CB6, /CD6, /CF6)

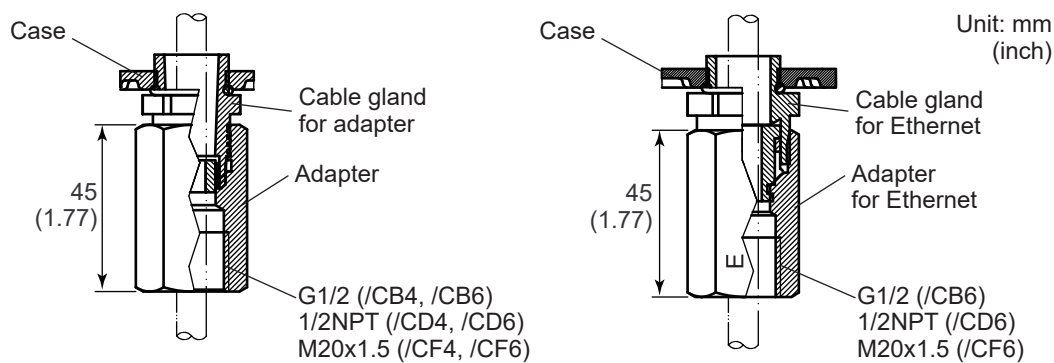

Note: Universal Mounting kit (/UM) contains pipe, wall mounting hardware (/U) and panel mounting hardware (/PM).

**Panel mounting hardware (/PM, /UM)**

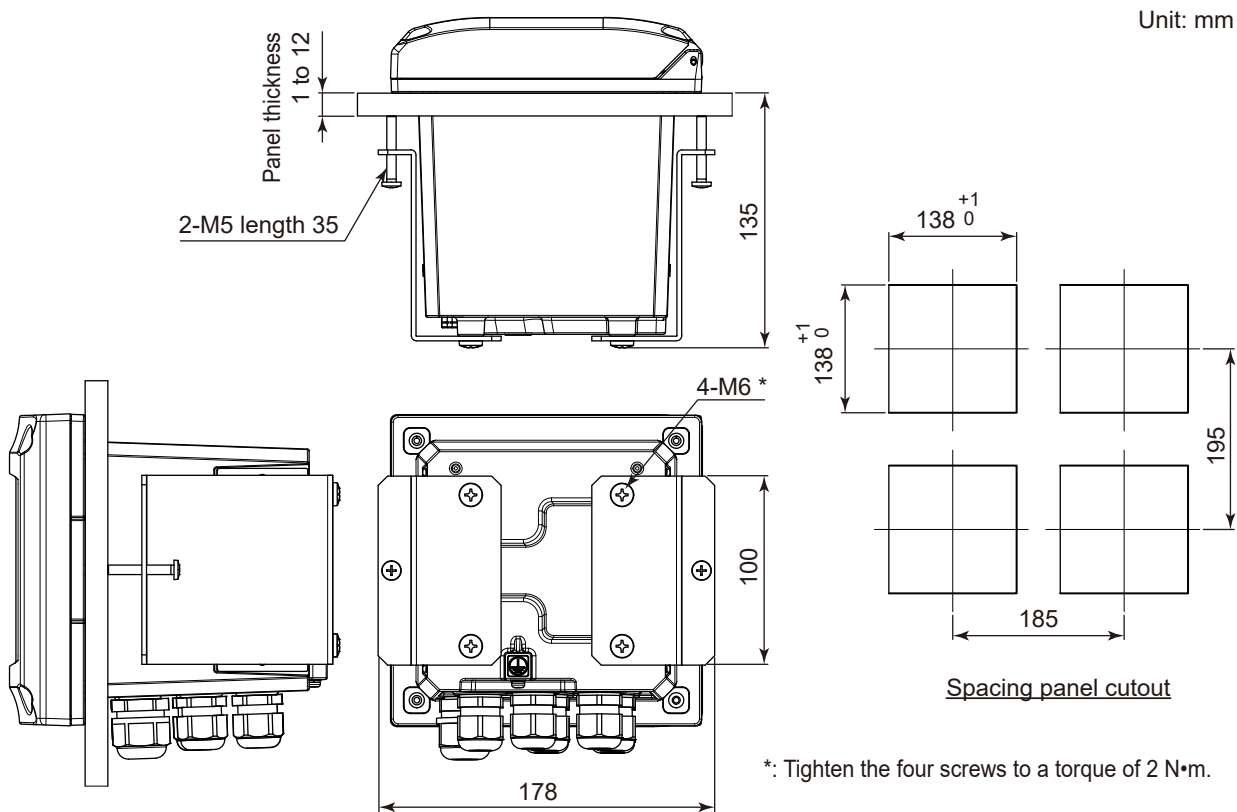

**Wall mounting hardware (/U, /UM)**

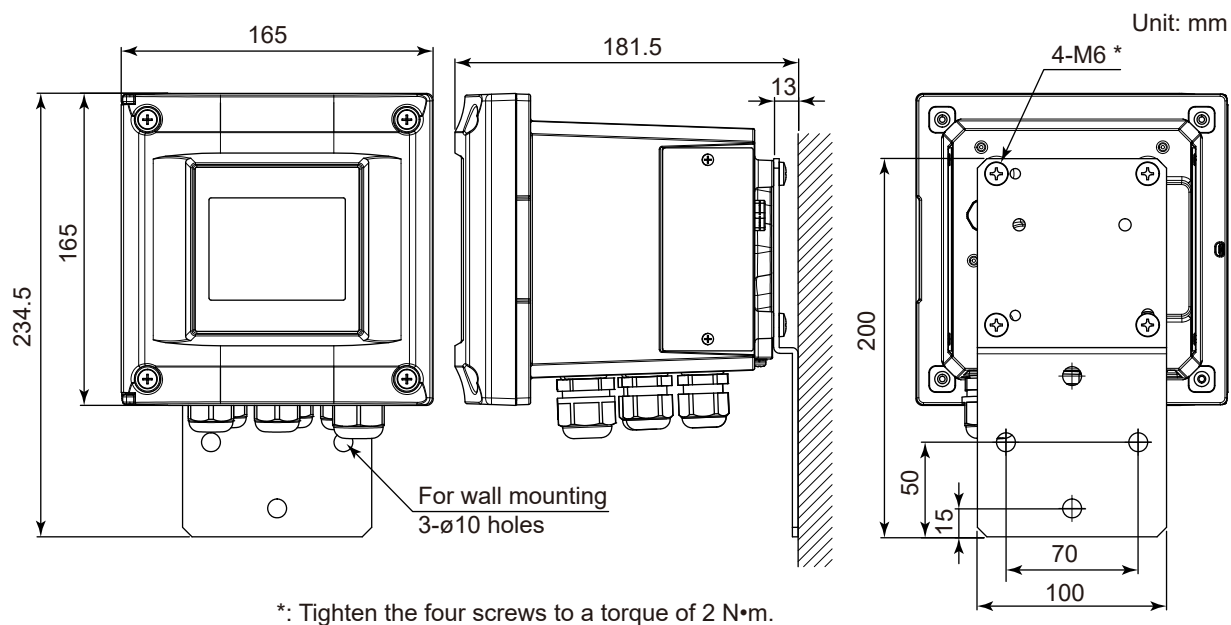

Note: For wall mounting, the wall should be strong enough to bear the weight of 8 kg or more.

**Pipe mounting hardware (/U, /UM)**

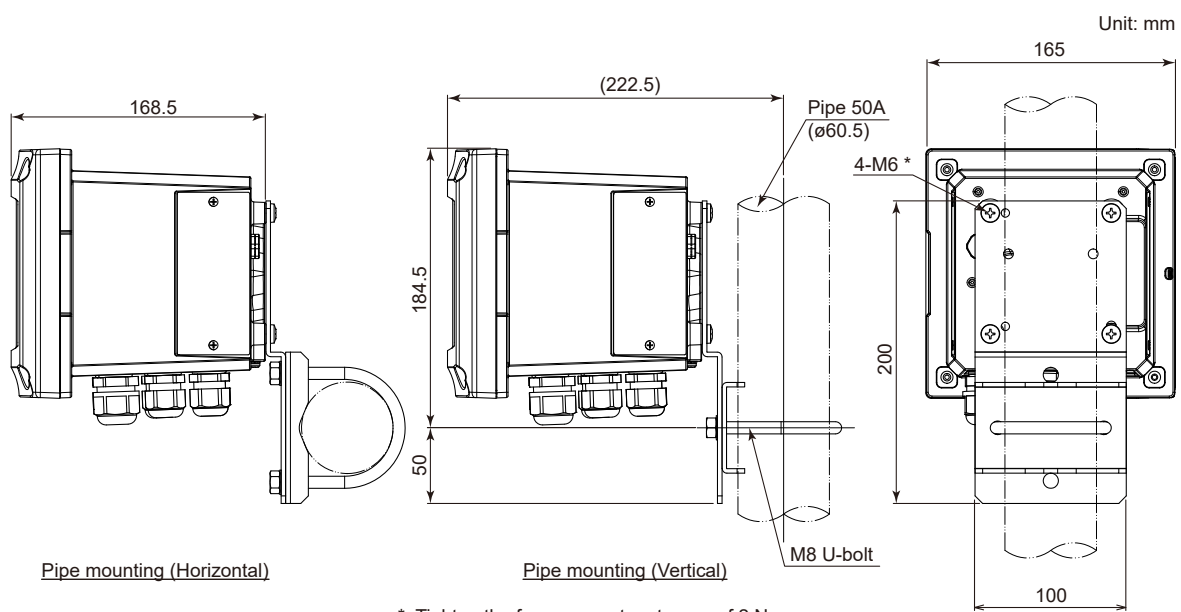

\*: Tighten the four screws to a torque of 2 N•m.

**Hood Stainless steel (/H6, /H7)**

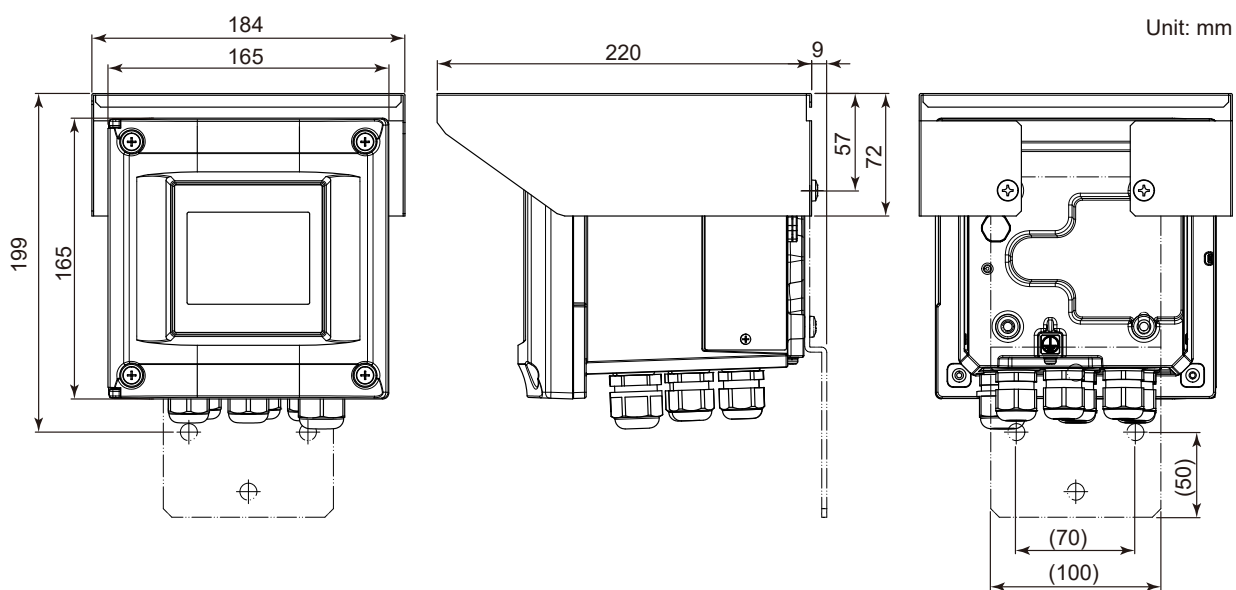

## ■ Wiring

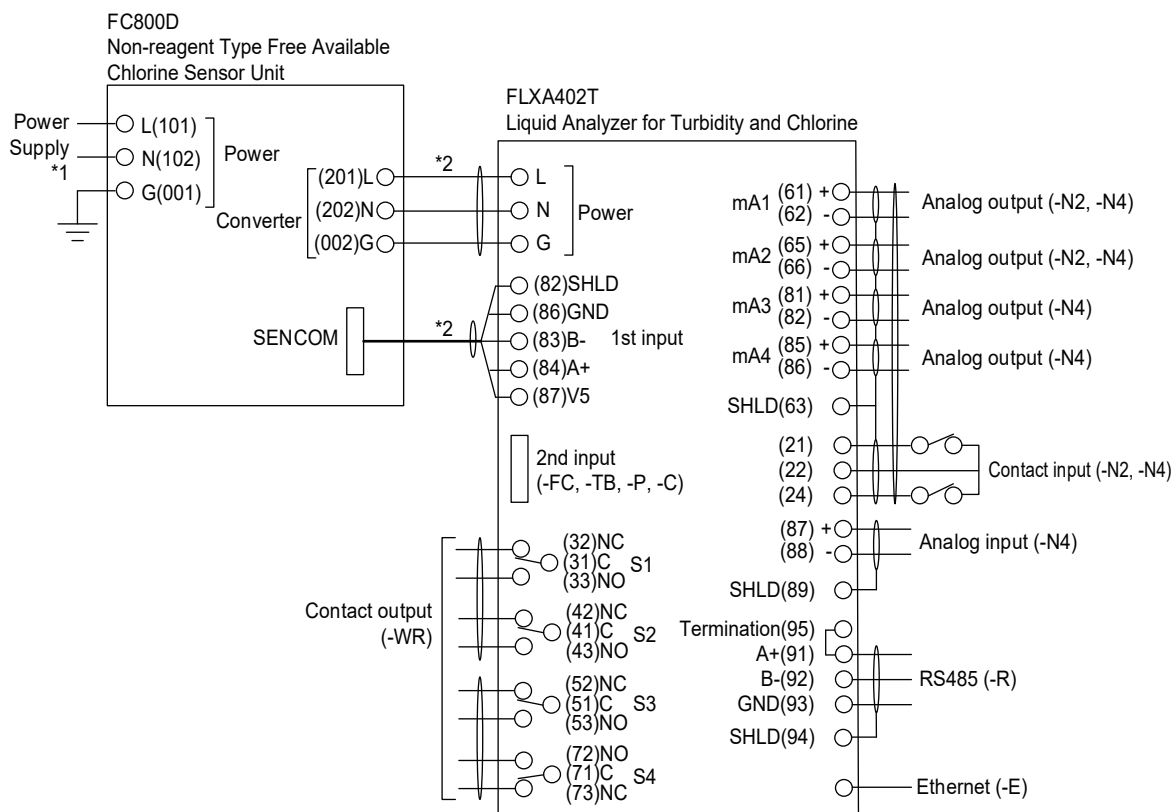

\*1: Power terminal "G" on Terminal Box must be grounded (ground resistance: 100 ohm or less).

\*2: Connection cable is normally 1 m in length. It is available with /L02, /L03, /L05, /L10 or /L20 depending on the length you need.

### With Terminal Box for connecting automatic wash/cal. valve (/TB)

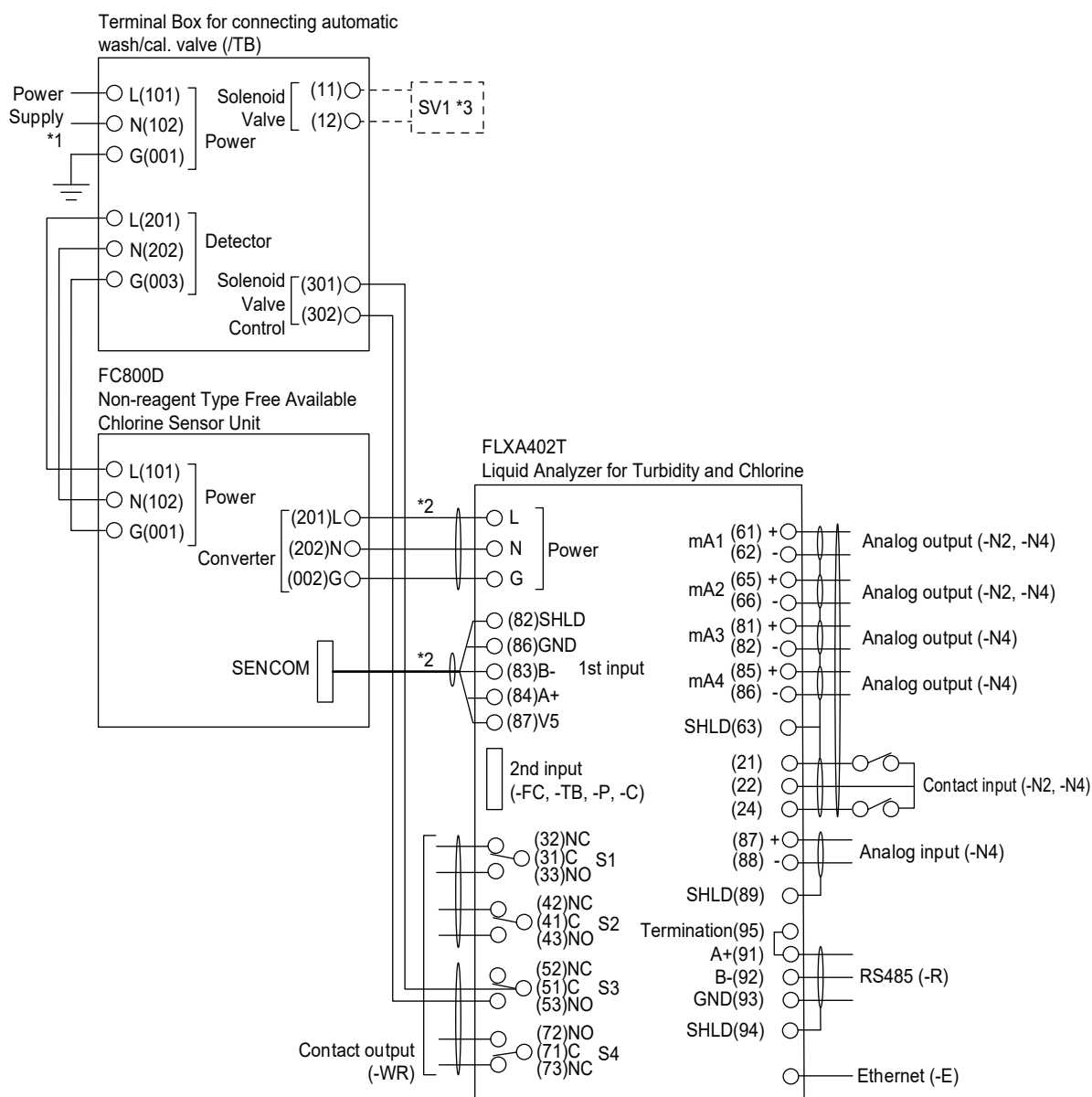

\*1: Power terminal "G" on Terminal Box must be grounded (ground resistance: 100 ohm or less).

\*2: Connection cable is normally 1 m in length. It is available with /L02, /L03, /L05, /L10 or /L20 depending on the length you need.

\*3: In case of selecting /TB (Terminal box for connecting automatic wash/cal. valve), purchase the solenoid valve corresponding input power supply and frequency. See ● Solenoid valve (SV1).

## Piping

Piping is connected to the measurement liquid inlet and drain outlet. The piping depends on the sampling equipment. The following figures show the examples of the piping.

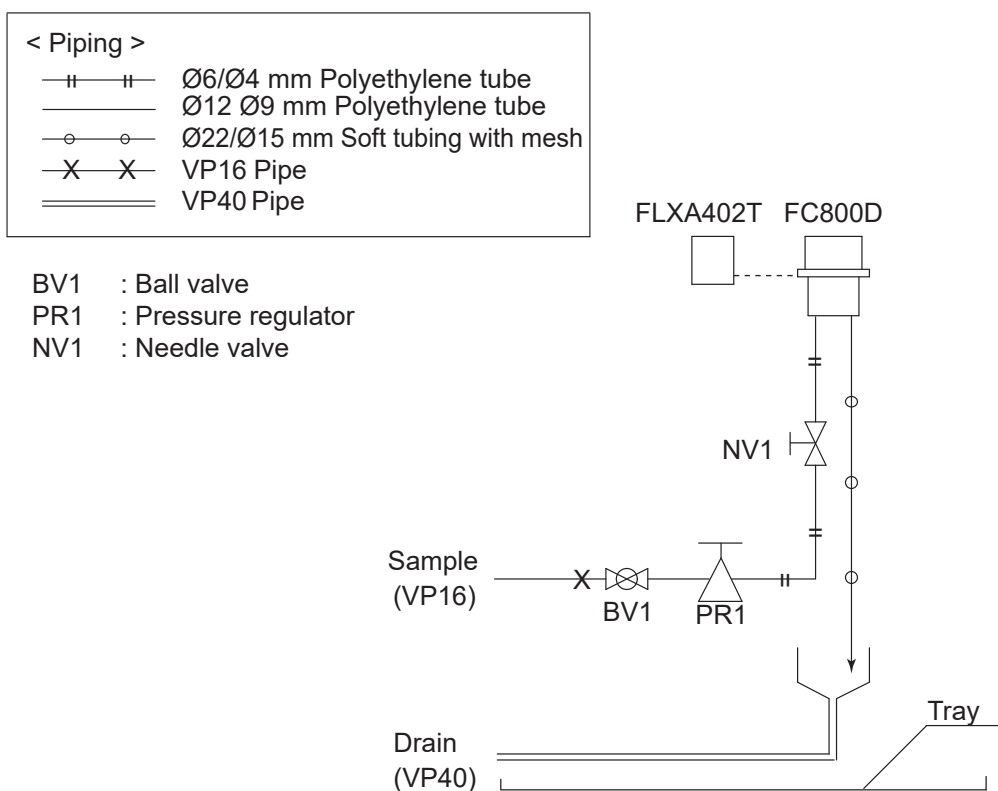

• With (/TB), for auto zero calibration for free available chlorine analyzer

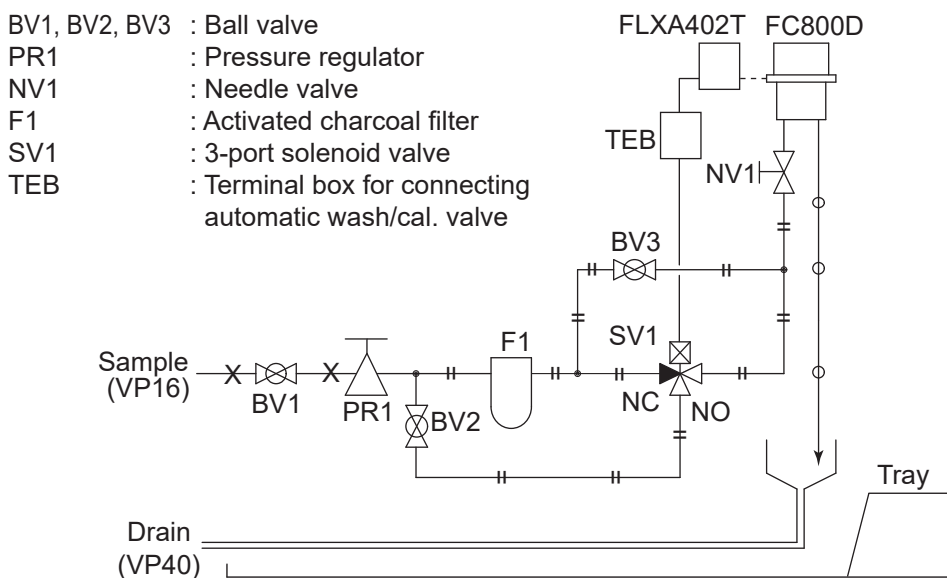

• With (/ST), for auto zero calibration for free available chlorine analyzer

- BV1, BV2, BV3 : Ball valve  
 PR1 : Pressure regulator  
 NV1 : Needle valve  
 F1 : Activated charcoal filter  
 SV1 : 3-port solenoid valve  
 TEB : Terminal box for connecting automatic wash/cal. valve

