

Smart Capacitive Level Switch

Model: MDCA5

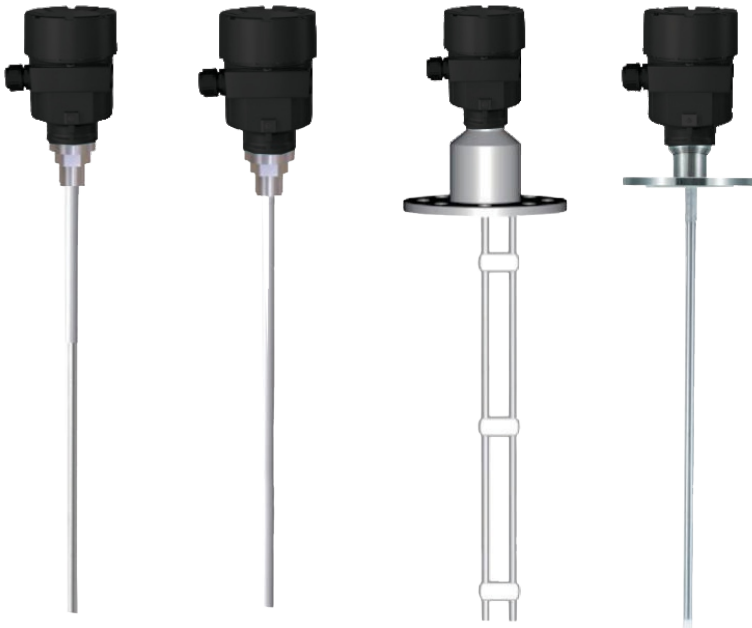

1. Product Overview

Smart capacitive level switch is the best upgrade product to replace the traditional capacitive level switch. It is a high-end instrument for point-to-point switch measurement, with stable performance and maintenance-free characteristics. The traditional capacitor level switch can only be set by adjusting the sensitivity knob of the instrument and can not display the parameters. Our intelligent capacitor level switch has a unique liquid crystal display that allows you to visually view the liquid crystal display of the instrument, at the same time, the instrument can be set up with one button on the liquid crystal display whether the material is empty or full. Our intelligent capacitor level switches are widely used in chemical medicine, plastic granule, film, feed, grain, rubber, liquid, waste water, sand, food, slurry, cement, powder material, coating, coal, granular solid, oil, pulp and other working conditions measurement.

2.Measurement Principle

The measuring electrode, dielectric and vessel wall form a capacitor. The capacitance of a capacitor is mainly affected by three factors. Here, the electrode and the vessel wall are the capacitor plates, and the dielectric is the dielectric. Because of the higher dielectric constant of the medium relative to the air, the capacitance of the capacitor increases with the increase of the covering degree of the electrode. The capacitance change is converted by the electronic plug-in into a switch instruction.

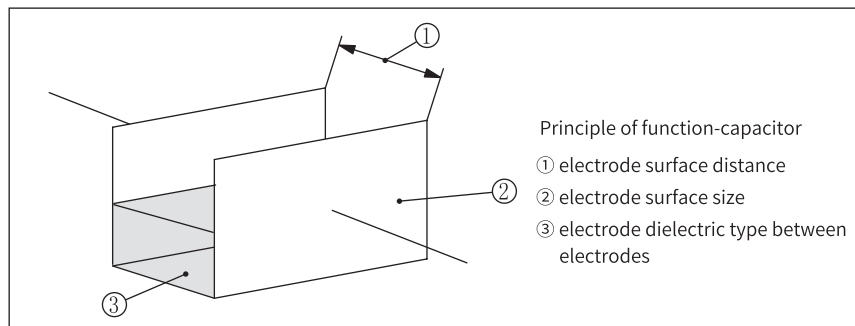

Fig 1

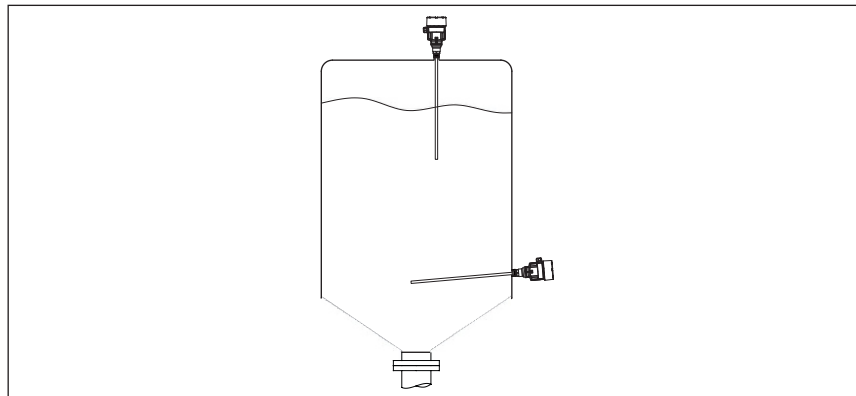





Fig 1

3.Introduction to Instrument

Model	MDCA51	MDCA52	MDCA53	MDCA54
Picture				
Features	LCD display, programmable, adjustable return difference, a key set empty, full bin, a key set high and low level alarm.			
Application	Measurement of particle position of solid powder	Measurement of liquid site	Two-rod probe for measuring the position of liquid in non-metallic storage tank	Measurement of corrosive liquid sites
Process temperature	- 60 °C ~ 200°C	- 60 °C ~ 150 °C	- 60 °C ~ 150 °C	- 60 °C ~ 150 °C
Probe material	Stainless steel /PTFE/FEP	Stainless steel /PTFE/FEP	Stainless steel /PTFE/FEP	Stainless steel /PTFE/FEP
Process connection	¾ " NPT thread/flange	¾ " NPT thread/flange	Composite anti-corrosion flange	Composite anti-corrosion flange
Probe length	Standard type 350/500mm Customization 500~3000mm			
Power supply	24 V DC/ 220 V AC			
Relative humidity	≤ 85 %			
Output signal	Relay (two sets of normally open and normally closed contacts) Transistor PNP			
Contact rating	24V DC/8A; 220V AC/5A			
Delay	0~99S(adjustable)			
Ambient temperature	-40~70°C			
Protection rating	Plastic case IP66/Aluminum case IP67			
Explosion-proof grade	Exd IIC T6 Gb			
Installation method	Top/side mount			

4. Mounting Requirements

(1) Basic Requirements

RF admittance level switches can be mounted anywhere in the vessel as long as there is no contact between the probe and material. The distance between probes should be no less than 0.5m if the vessel is equipped with alarms of higher and lower level limits.

Pay attention to the following precautions during the selection of cable probe for switches control:

- ① The distance between probe and sidewall should be no less than 30 mm.
- ② When the steel cable probe measures solid particles, the roof of the vessel must be strong enough to withstand the downward pulling force of the medium.
- ③ It's recommended to use tightening loops at the bottom to bear the min. horizontal force when measuring by steel cable probe.

(2) Mounting

During the mounting of the standard model, the insulation part needs to be extended over 30mm out from the connecting pipe to avoid malfunction caused by stockpile of materials in pipe; or the sensitivity cannot be adjusted since the distance between the connecting pipe and the detector bar is too close. (Fig 2)

The detector bar and the canister wall should keep at least 300mm during the mounting. (Fig 3)

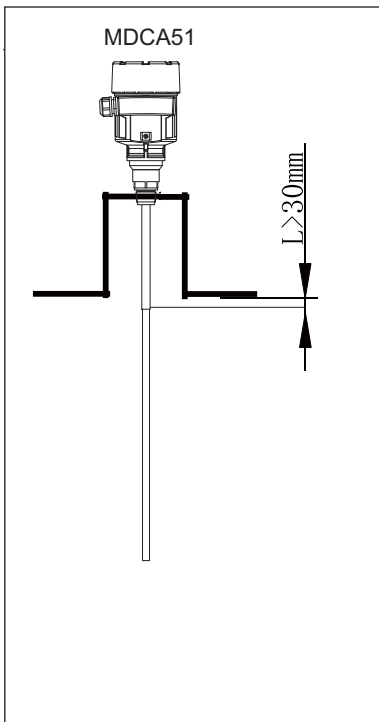

Fig 2

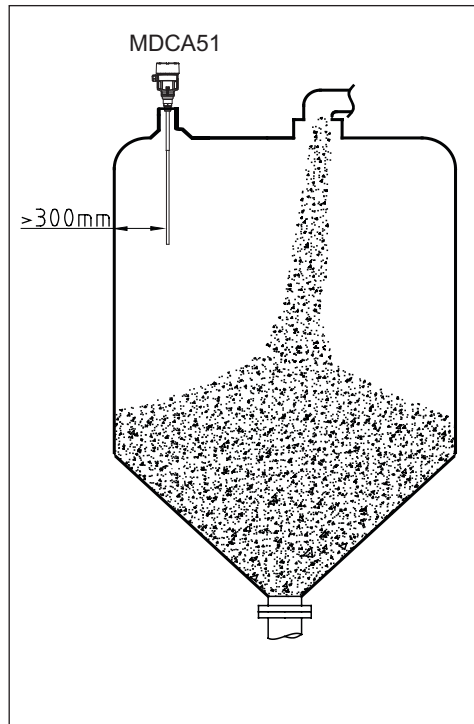

Fig 3

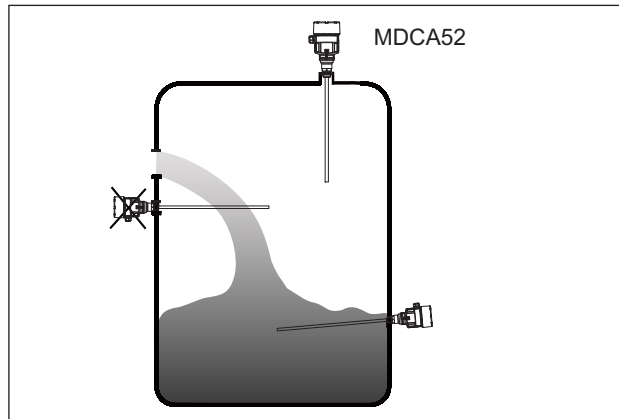

Fig 4

If the RF admittance level switch is used to measure liquid, please do not be installed under the water inlet to avoid malfunction caused by water (or other liquids) dripping on the probe.

(3) Stirring

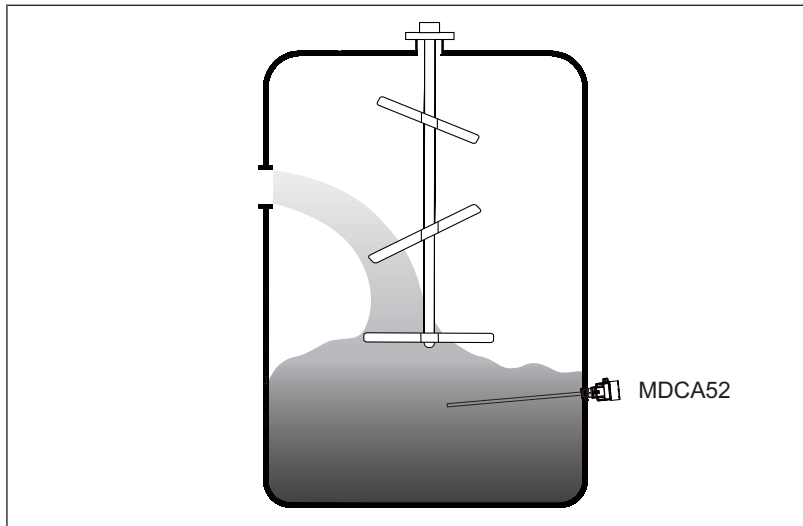

Fig 5

If the radio frequency admittance level switch is mounted in a canister with stirring device, delay function should be set to avoid malfunction caused by fluctuation.

7. Display/Adjustment Setting Module Menu

The four keys on programmable display can be used for the setting of instrument parameters (as shown in the picture below). Normally the programmable display is used on site display after commissioning or it may be removed.

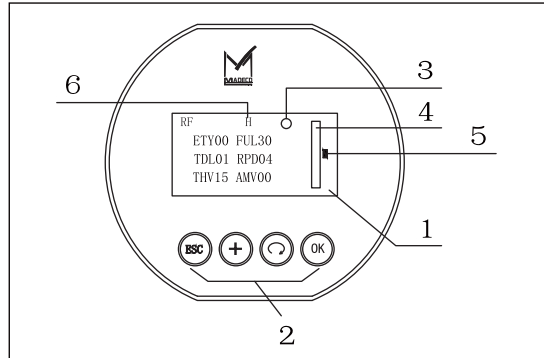

Fig 7

(1) Interface Operating Instructions

①LCD display ②Button ③Relay triggering indicator (○ means the relay is always open, ● means the relay is closed after triggered) ④Measurement value display ⑤ Hysteresis error range ⑥Display of high and low level

- ▶ Empty: measurement value or set value when the material level is empty
- ▶ Full: measurement value or set value when the material level is full
- ▶ Delay: trigger delay time of relay (unit: Second)
- ▶ Threshold value:

Alarm threshold value of high material level switch:

Alarm condition= $\left(\frac{\text{Full value} + \text{Empty value} + \text{return difference}}{2} \right)$ continuous holding time is greater than or equals to delay time

Cancel alarm condition= $\left(\frac{\text{Full value} + \text{Empty value} - \text{return difference}}{2} \right) - 1$ continuous holding time is greater than or equals to delay time

▶ Alarm threshold value of low material level switch:

Alarm condition= $\left(\frac{\text{Full value} + \text{Empty value} - \text{return difference}}{2} \right) - 1$ continuous holding time is greater than or equals to delay time

Cancel alarm condition= $\left(\frac{\text{Full value} + \text{Empty value} + \text{return difference}}{2} \right)$ continuous holding time is greater than or equals to delay time

- ▶ Actual measurement: actual measurement value (displayed in relative %)

(2) Operating Instructions

Manual setting: empty, full, delay, return difference.

Press **OK** key enter into manual setting; select the setting parameters for manual modification;

Continuously press **OK** key for selection in sequence: press **OK** key to select [Empty]; and then press **OK** key to select [Full]; and then press **OK** key to select [Delay]; and then press **OK** key to select [Return difference]; the selected parameters will be displayed in black. After selecting the to-be-modified parameters, press **+** key and **↻** key to plus or minus parameter.

After settings, press **ESC** key to exit manual setting status. (or the system will exit manual setting on itself if no button is pressed over 2 minutes after setting)

► Operation of Shortcut Keys

Set full value: press **ESC** key + **+** key while making the current system measurement as full value. (Normally it's used when the measured object is in full material level)

Set empty value: press **ESC** key + **↻** key while making the current system measurement as empty value. (Normally it's used when the measured object is in empty material level)

System restores default value: press **+** key + **↻** key at the same time, the empty value, full value, delay value and return difference value will be set as the restores default value.

Switch high/low material level: press **+** key and **OK** key at the same time.

Switch Chinese/English: press **ESC** key and **OK** key at the same time.

8. Structure & Dimension (Unit: mm)

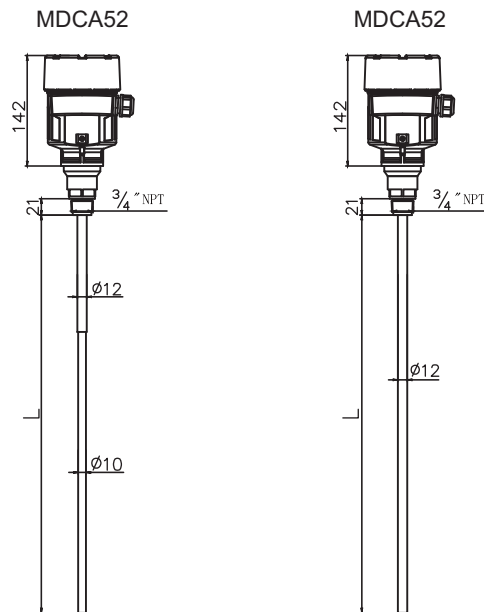

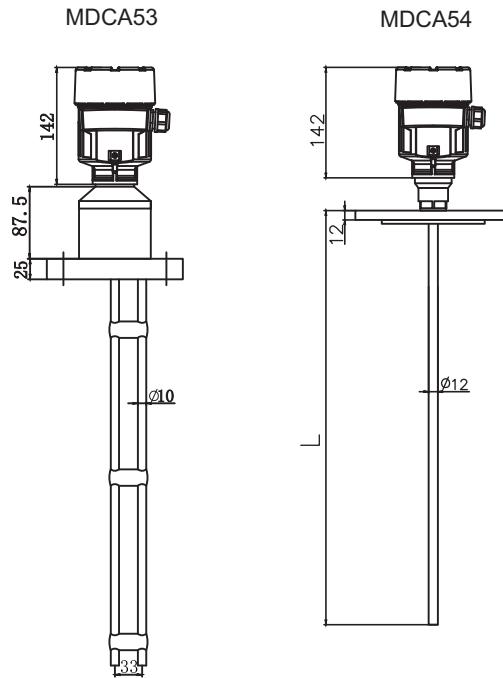

9. Transport and storage

In addition the transport and storage conditions shall comply with the following requirements:

1. The level shall be transported in strict accordance with product characteristics and specifications during transportation.
2. The level should be stored in dry ventilated rooms with a relative humidity of $-20\text{ }^{\circ}\text{C}$ to $60\text{ }^{\circ}\text{C}$ and not more than 80%. Do not mix with corrosive substances. After long-term storage of the instrument should be carried out after the corresponding test can be sold, use.



Address: 7191 Yonge street, Toronto, Canada

Tel: +16472221281(5 line)

Web: www.madecotech.com

Email: Info@madecotech.com