

Liquid Tuning Fork Level Switch

Operating Instruction

Model : MDFL5



1. Product Overview

1.1 Principle

The tuning fork is driven piezoelectric and vibrates at a mechanical response frequency of about 1200HZ. The piezoelectric structure is mechanically fixed and therefore not subject to the limit of sudden temperature change. If the tuning fork is covered by a medium, the frequency will change. This change is detected by the built-in electronic unit and converted into a switching instruction.

A tuning fork is a compact instrument that can be operated without external analysis. The built-in electronic components analyze the level signal and convert it into a switch signal. Using this switch signal can directly operate a rear-mounted instrument (such as an alarm device, a pump, etc.) .

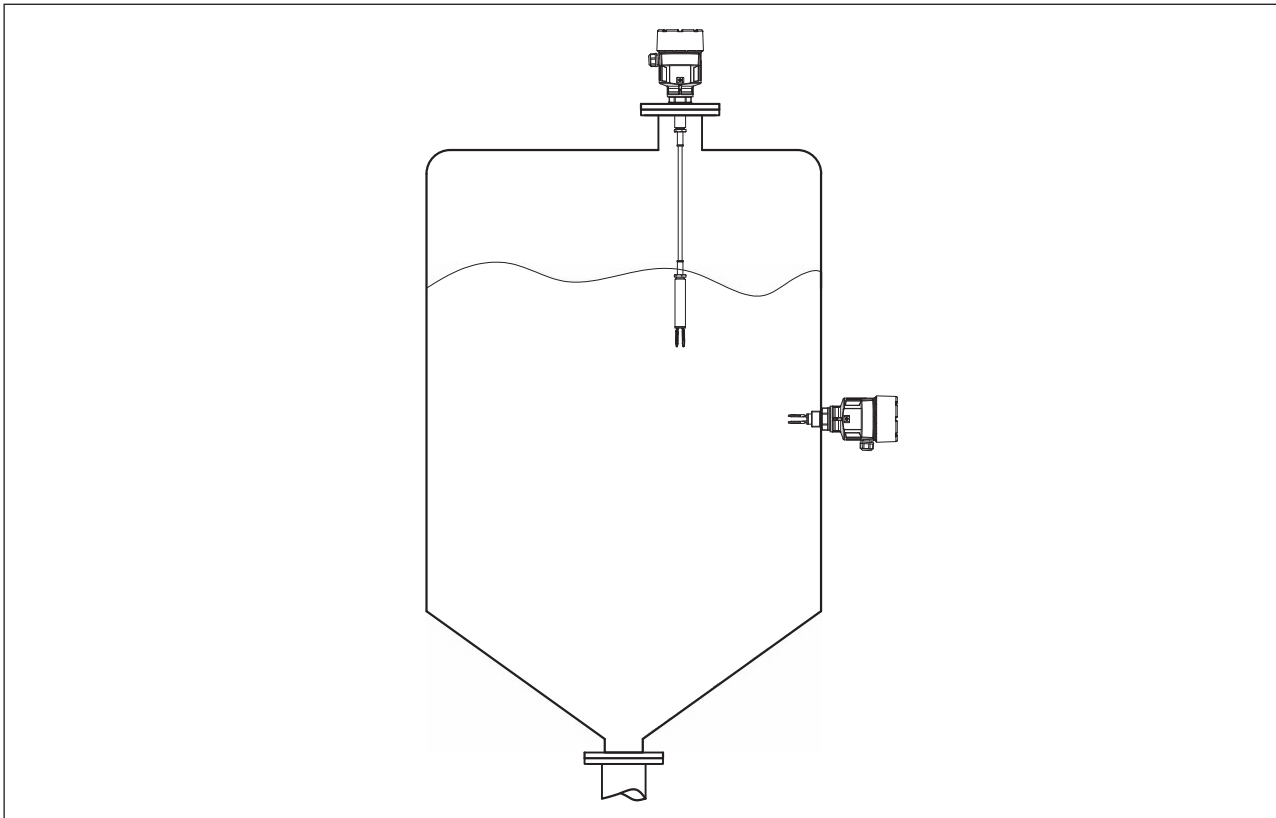

Figure 1

1.2 Application

Liquid tuning fork level switch is a limit level sensor with tuning fork, which is used to measure the limit level. It is designed for industrial applications in all process areas and is used in liquid applications. Can be installed in pipes above DN32 and can be used in containers, tanks and pipes. With its simple and robust measurement system, it is almost impervious to the chemical and physical properties of liquids.

It can also work under complex and harsh measuring conditions, such as eddy current, bubbles, foams, attachments, severe external vibration or transformed media.

3. Installation

3.1 Basic Requirements

In principle, you can install a tuning fork position switch in any position. Just be aware when installing the instrument that the tuning fork must be at the desired switch point height. A tuning fork is marked on the side as a switch point for vertical mounting. The switch point is mainly used for the measurement of medium "Water" in the basic setting of a density switch $\geq 0.7 \text{ g/cm}^3$.

Note when installing:

- ① The alarm point mark should be at the desired switch point height.
- ② If the density of the medium is different from that of water, the switch point of the meter will move (water 1 g/cm^3).
- ③ If $0.47 \text{ g/cm}^3 < \text{dielectric density} < 0.7 \text{ g/cm}^3$, the density switch should be set to $\geq 0.5 \text{ g/cm}^3$.
- ④ A foam density of 0.45 g/cm^3 will be detected by the sensor. This can lead to switching failure, especially when used as an operating protection device.

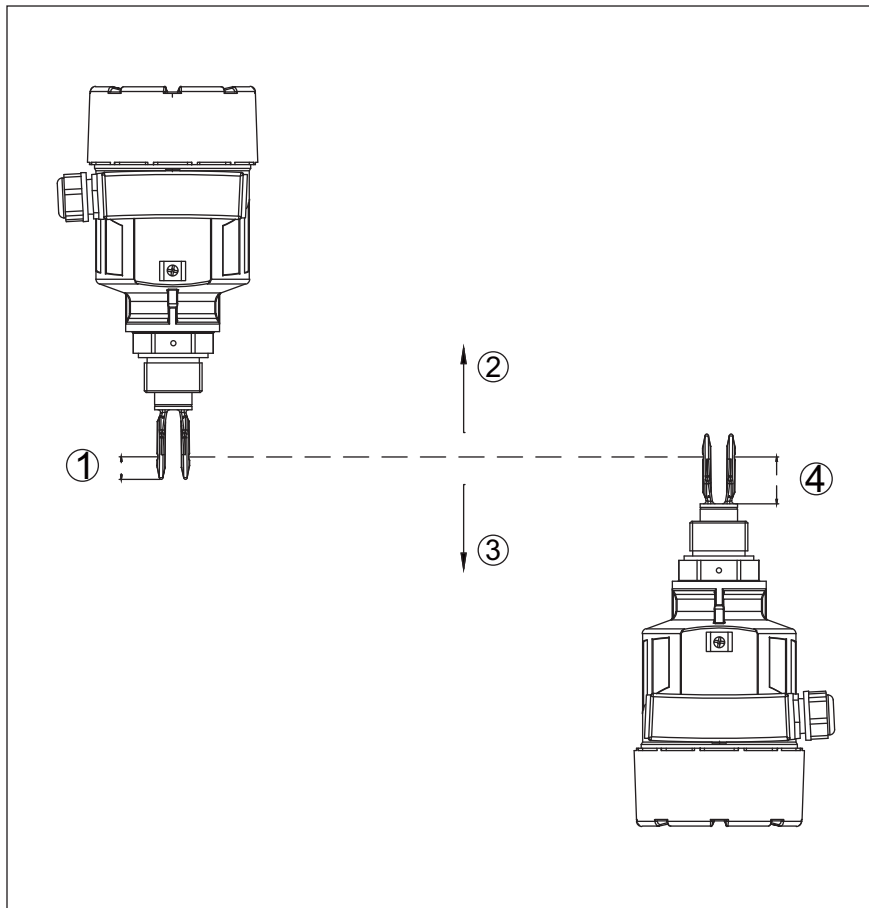

Figure 2

- | | |
|---------------------------------------|--|
| ① The switching point is about 13mm | ② The switching point at lower density |
| ③ The switching point at high density | ④ The switching point is about 27mm |

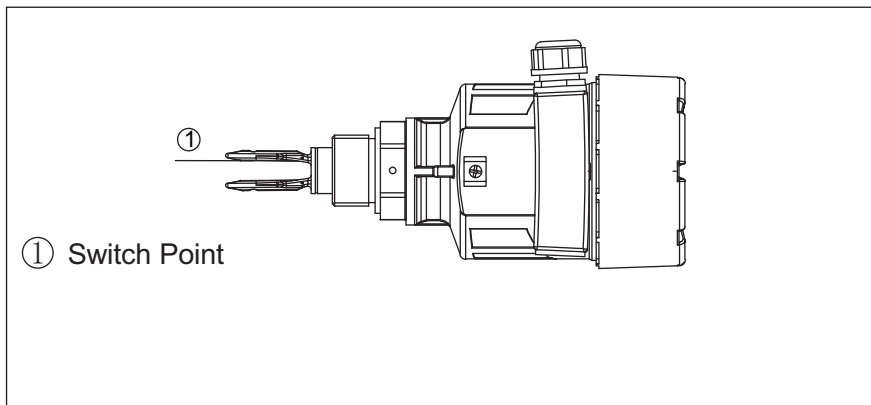

Figure 3 Horizontal installation

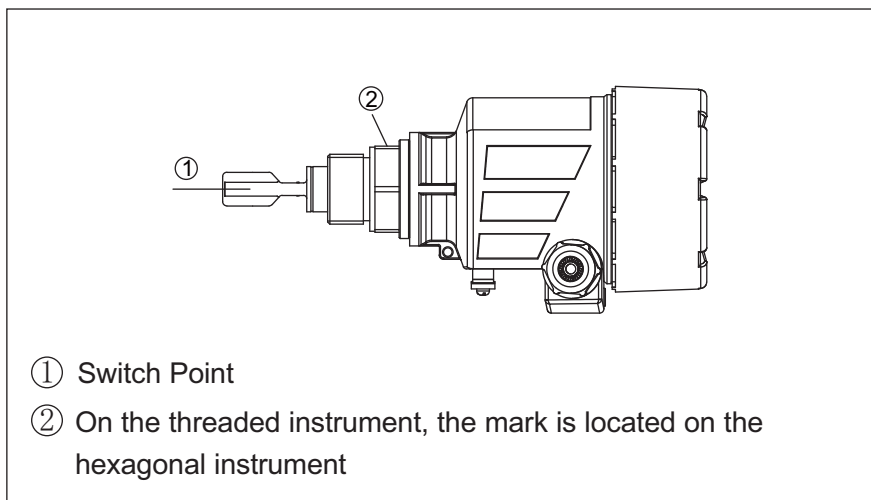

Figure 4 Horizontal mounting
(recommended mounting position, mainly for adhesive media)

For the flange type, the tuning fork is aligned to the flange hole in the following manner.

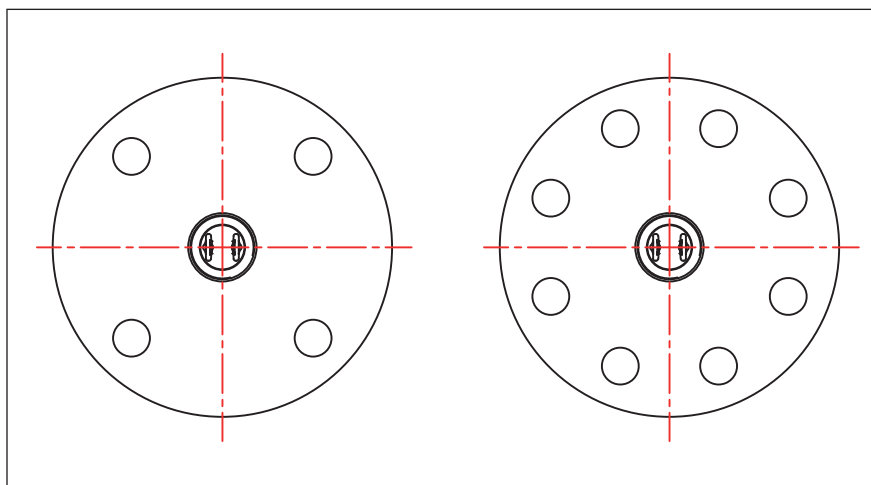

Figure 5 The position of the tuning fork on the flange

3.2 Installation Instructions

In principle, you can install a tuning fork position switch in any position. Just be aware when installing the instrument that the tuning fork must be at the desired switch point height. A tuning fork is marked on the side as a switch point for vertical mounting. The switch point is mainly used for the measurement of medium "Water" in the basic setting of a density switch $\geq 0.7 \text{ g/cm}^3$.

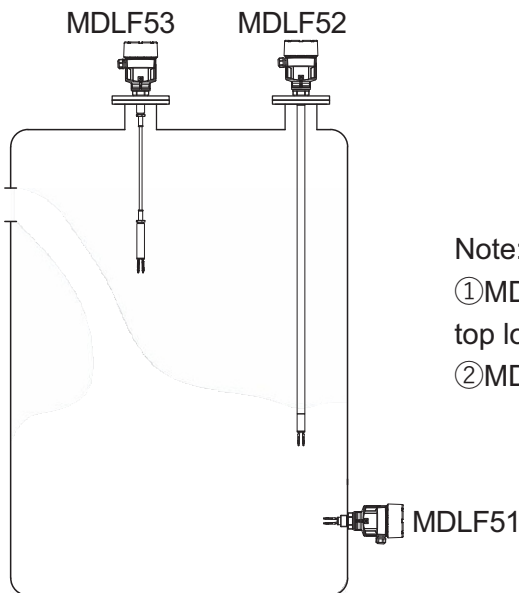

Figure 6

Note:

- ① MDLF51 is generally used for side loading, and the top loading is used for narrow storage tanks.
- ② MDLF52, MDLF53 using top-mounted.

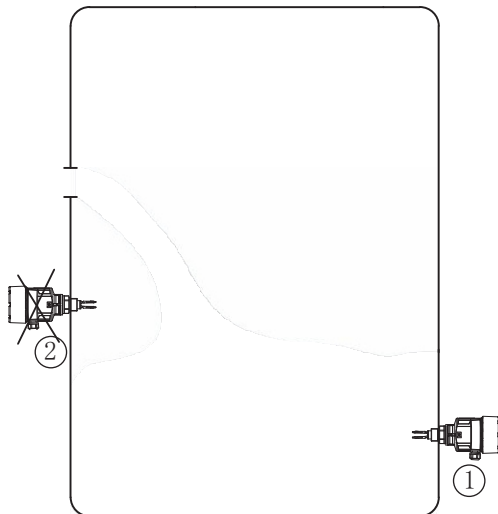

Figure 7

Typical error installation can not be installed below the inlet, also note: outdoor installation should take shading, rain-proof measures.

- ① Right
- ② wrong

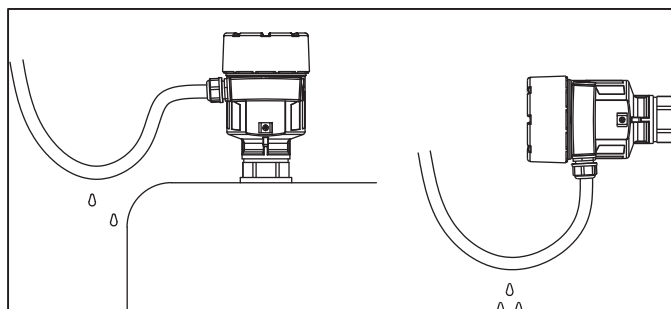

Figure 8

Moistureproof for installation in outdoor or wet environment, should tighten the cable sealing sleeve, but also in the entrance to make the cable downward bend into U-shaped. As shown in Figure 8:

Protection rating

This instrument fully meets the protection grade IP67 requirements, please ensure that the cable sealing head waterproof. Below:

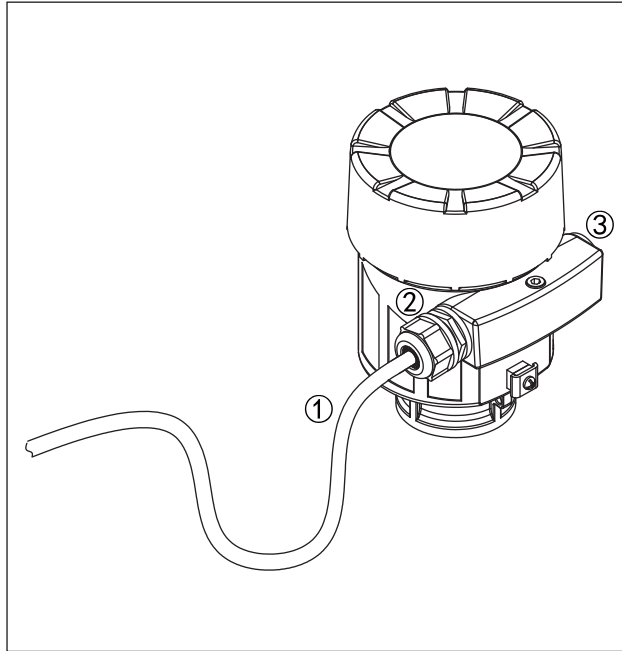

Figure 9

How to ensure that the installation meets

IP67 requirements:

- ▶ Please make sure the sealing head is not damaged
- ▶ Please make sure the cable is not damaged
- ▶ Please ensure that the cable used meets the requirements of the electrical connection specification by bending the cable downward before entering the electrical interface to ensure that water does not flow into the housing, See①
- ▶ Please tighten the cable seal head, See②
- ▶ Please tighten the unused electrical interface with blind plug, see③

When the adhesive medium is installed horizontally in the adhesive and viscous medium, the tuning fork surface should be kept as vertical as possible so as to minimize the sediment on the tuning fork. There is a mark on the threaded hexagon so that you can check the position of the tuning fork when you screw it in. If the hexagon is on the gasket, you can also continue to rotate the thread about half a turn, so that the recommended installation position can be fully achieved.

For the flange type, the tuning fork is aimed at the flange hole. In adhesive and viscous media, tuning forks should be extended as far as possible unobstructed into the container to prevent deposition. Therefore, the use of flanged bushings and screw-in joints should be avoided during horizontal installation.

In a flowing medium, the tuning fork surface should be parallel to the movement of the medium so that the liquid fork of the MDFL5 will cause as little resistance as possible.

Note: If the existing medium into the vibration element, you need to immediately replace the instrument.

4. Electrical Connection

- ▶ Safety tip: only allow wiring in the state of power failure.
- ▶ Power supply: electronic plug-ins with relay output have Class I protection. To maintain this level of protection, the grounding wire must be connected to an internal grounding wire connection terminal.

Connecting cable: this instrument and the market common without shielding three-core wire cable connected. Shielded cables should be used if the expected electromagnetic spurious values exceed the standard test values applicable to the industrial field. Please use cable with round section, diameter 6 ~ 9mm cable, ensure the sealing of cable thread joint. If you are using cables with other diameters or cross sections, replace the seals or use a suitable threaded connection for the cable.

- ▶ Explosion-proof application connection cable: Please use the approved cable threaded connection in the explosion-proof area.

- ▶ Wiring procedure:

For explosion-proof instruments, the housing cover may be opened only if an explosive atmosphere is not present.

The steps are as follows :

- ① Unscrew the cover
- ② Loosen the lock nut on the cable threaded joint
- ③ Remove about 10 cm of skin from the connecting cable and about 1 cm of insulation from the end of the core wire
- ④ Insert the cable through the cable threaded connector into the instrument housing
- ⑤ Open the connecting terminal with a screwdriver
- ⑥ Insert the mandrel end into the open terminal according to the wiring diagram
- ⑦ Tighten the connecting terminals with a screwdriver
- ⑧ The position of the wire in the terminal can be checked by pulling it lightly
- ⑨ Tighten the lock nut of the threaded connection of the cable. The sealing ring must completely enclose the surrounding cable
- ⑩ Screw on the housing cover, electrical connection is completed.

5. Wiring

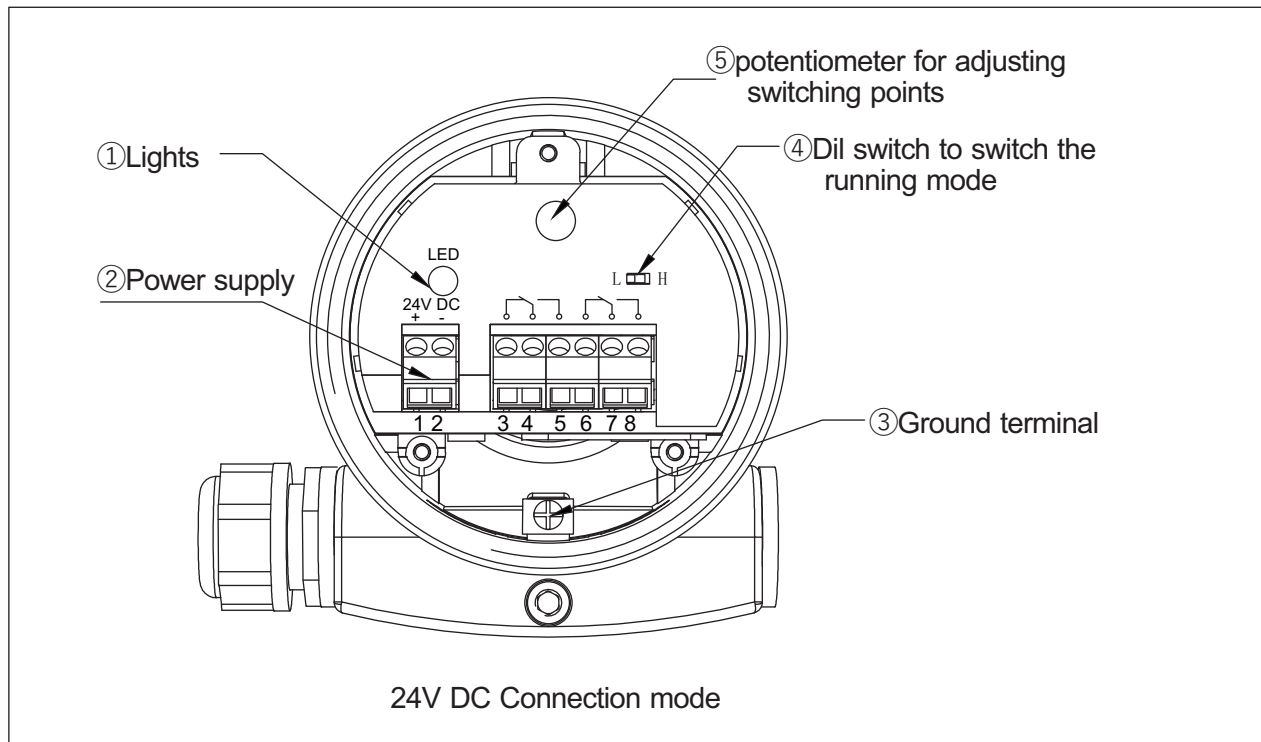

Figure 10

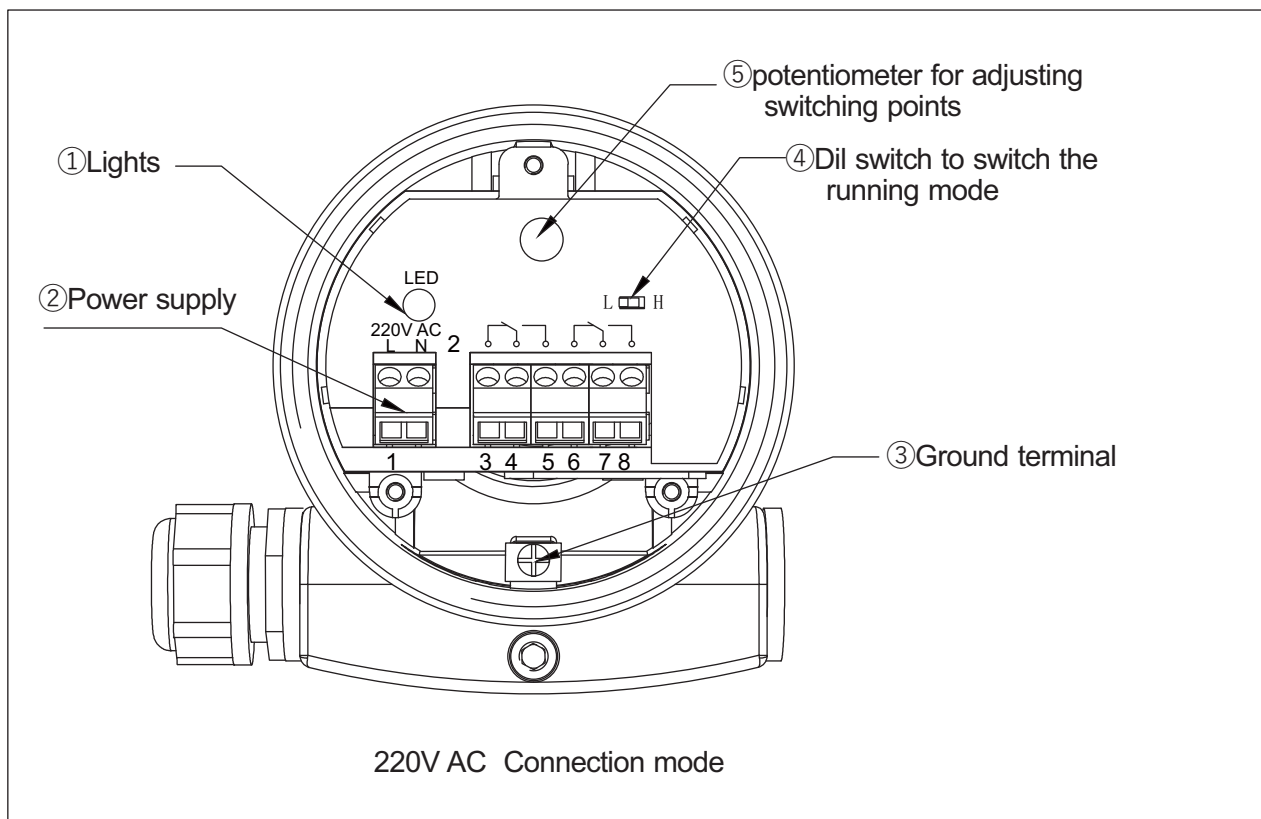

Figure 11

Terminal definition:

- (1)1, 2 Power supply; (2)3, 6Normally closed contacts; (3)4, 7Public End;
 (4)5, 8Always Open contacts

Wiring diagram

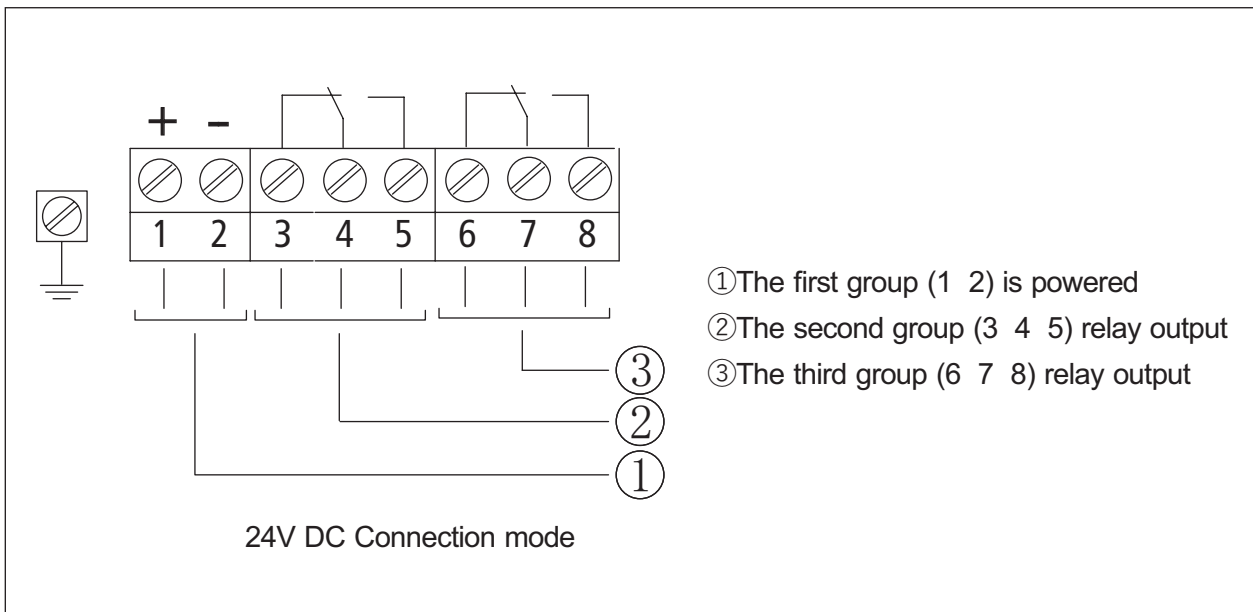

Figure 12

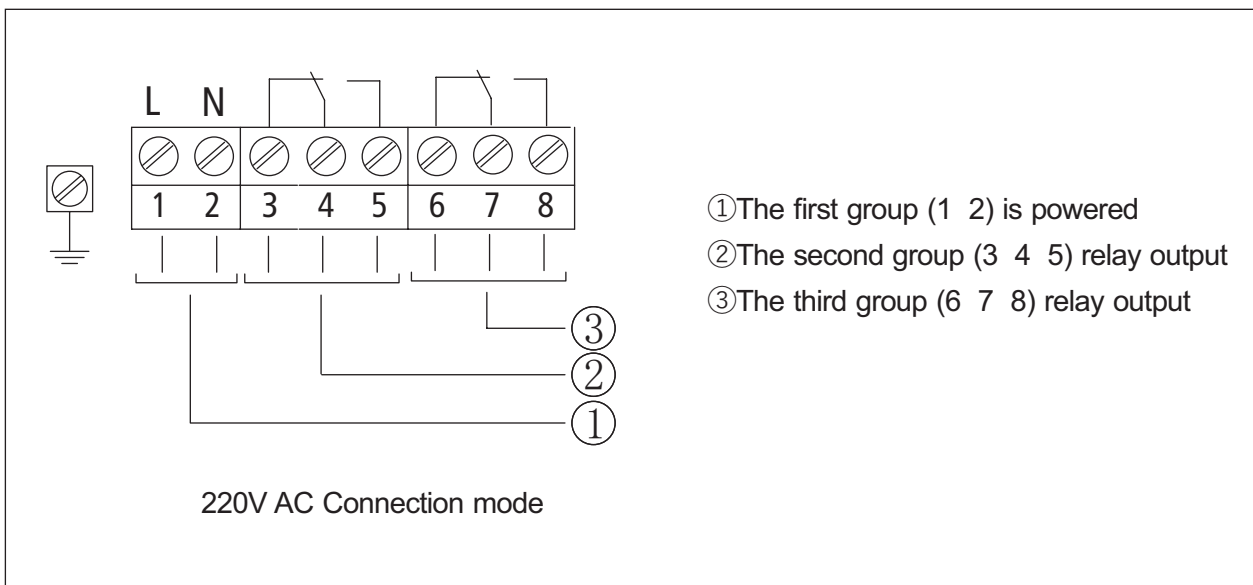

Figure 13

6. Instrument Adjustment

6.1 Function/Structure

Note: figures in parentheses refer to the following figures. Media density $\geq 0.7 \text{ g/cm}^3$ can be detected in the basic setting. For lower-density media, you must place the switch at $\geq 0.5 \text{ g/cm}^3$.

Note: keep the fork of MDFL5 in the liquid at all times during testing. Don't use your hands to test the functionality of the MDFL5, which can damage the sensor.

6.2 Adjust The Switch

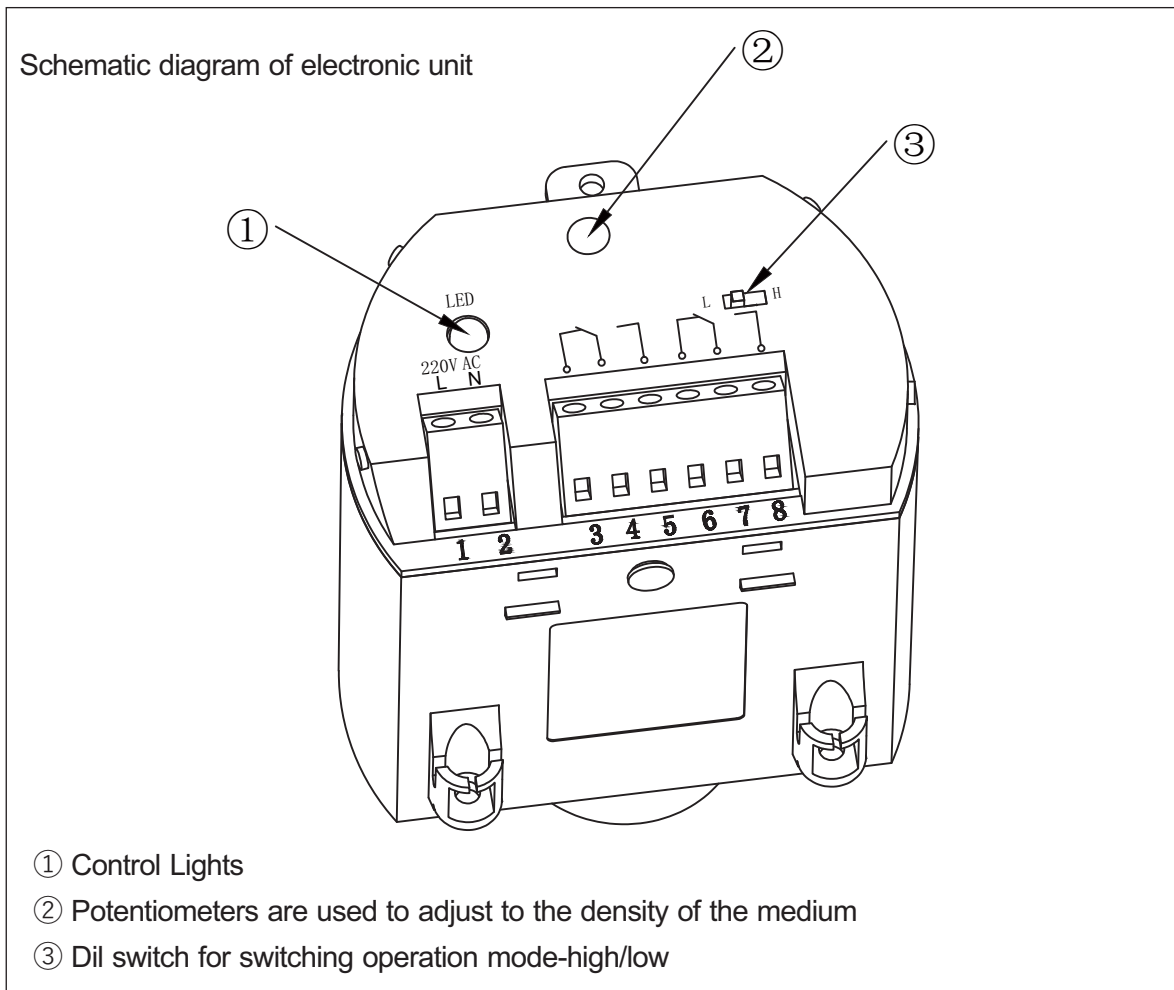

Figure 14

6.2.1 Control Lights

light used to indicate the status of a switch

Green = conductive relay

Red = relay no current

Red light (flashing) = fault

6.2.2 Convert The Running Mode

The switching state of the relay can be changed by changing the operating mode (H/L) . You can then set the desired mode of operation (h-max position measurement or overflow protection, L-min position measurement or dry operation protection) according to the "Function sheet".

6.2.3 Sensitivity Conversion











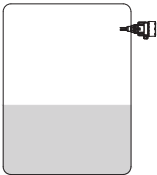
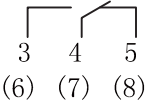

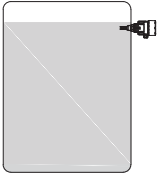
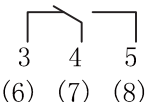
Using Dil Switch³, the switch point can be adjusted to a liquid with a density between 0.5 and 0.7 g/cm³. Liquids with a density of ≥ 0.7 g/cm³ can be detected in basic settings. For lower density media, you must position the switch at ≥ 0.5 g/cm³. Description of switch point position for medium "Water"-density value 1g/cm³. For media with different densities, the switch point moves to the housing or tuning fork baffle depending on the density and mounting method.

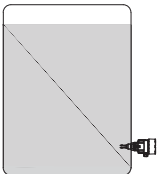
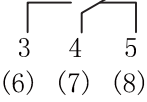
6.2.4 Note

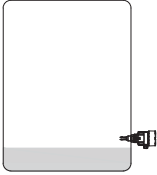
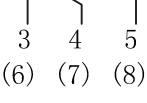
A foam density of 0.45 g/cm³ will be detected by the sensor. Especially when it is used as a dry-running protection device, it may cause the switch function failure.

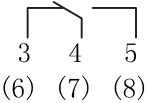
Function Table

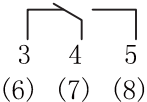
The following table shows the switch status in relation to the operating mode and object position that is set.

	Level	Switch state	Indicator lamp
Operation mode H overflow alarm		 Conductive relay	 Green
Operation mode H overflow alarm		 No current in relay	 Red
Operation mode L overflow alarm		 Conductive relay	 Green
Operation mode L overflow alarm		 No current in relay	 Red
Power supply interruption (operating mode H/L)	Arbitrary	 No current in relay	 Closing
Fault	Arbitrary	 No current in relay	 Flashing red light

7. Size (unit: mm)

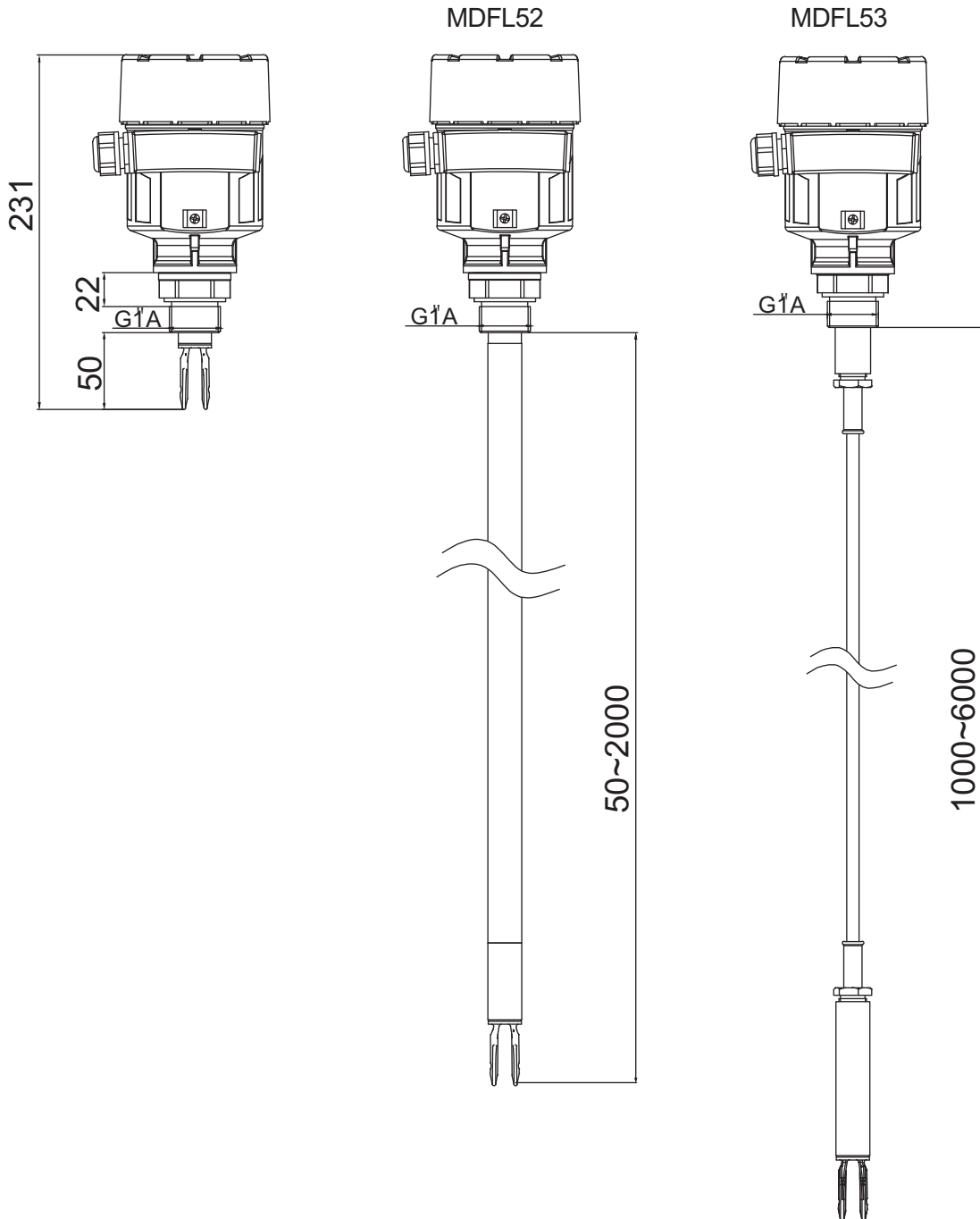

8. Technical Parameters

General parameters

Model	MDFL51	MDFL52	MDFL53
Process connection	G1"A	G1"A	G1"A
	flange	flange	flange
Process pressure	-0.1~6.4 MPa	-0.1~5.0 MPa	-0.1~0.3MPa
Tuning fork material	316L	316L	316L
Weight	1.2KG	1.2KG	3KG

Process pressure depends on the process joints, such as flange, thread, etc. .

Supply voltage	24V DC/220V AC	
Cable parameters	Cable line interface	One M20 × 1.5 cable inlet (cable diameter 6 ~ 9 mm) and one blind plug M20 × 1.5
	Spring terminal	For wire cross section 2.5 mm ²
Output parameters	Output signal	Relay (two sets of normally open and normally closed contacts); two-wire 8/16mA; transistor PNP.
	Contact capacity	24V DC/8A; 220V AC/5A
	Output delay	About 500ms (on/off)
The shell	Shell material	AL
	Sealed	Fluorine glue
	Shell window material	PC
	Ground terminal	stainless steel
Installation environment	Relative air humidity	45 ~ 75%
	medium density	1 g/cm ³ (water)
	medium viscosity	1 mPas
	Measurement variables	The limit level of a liquid
	Viscosity-dynamic	0.1 ~ 10000mPa s (condition: when density is 1)
	Velocity of flow	Maximum 6m/s (when viscosity is 10000 mPas)

Power	When the alarm about 0.23 W (DC) , do not alarm about 1W (DC)	
Measuring frequency	About 1200 Hz	
Installation mode	Install the sensor	Top/side loading
Accuracy	Precision	±1mm
	Lag	Vertical installation is about 2mm
Process conditions	Maximum test pressure	1.5 times the process pressure
	Process temperature (the temperature below the thread or flange) -50°C~150°C	
	Process temperature (thread or flange temperature) with high temperature adapter -50 ° C ~ 250 ° C (PMDLF51/MDLF52 only)	
Run the mode switch	H	Maximum level measurement or overflow protection /overflow protection
	L	Minimum level measurement or dry run protection
Density conversion switch	≥0.5g/cm ³	0.5~2.5g/cm ³
	≥0.7g/cm ³	0.7~2.5g/cm ³
Electrical protection measures	Protection	Aluminum IP67/plastic IP66
	Overvoltage level	III
	Protection level	I

Effect of process temperature on switching point

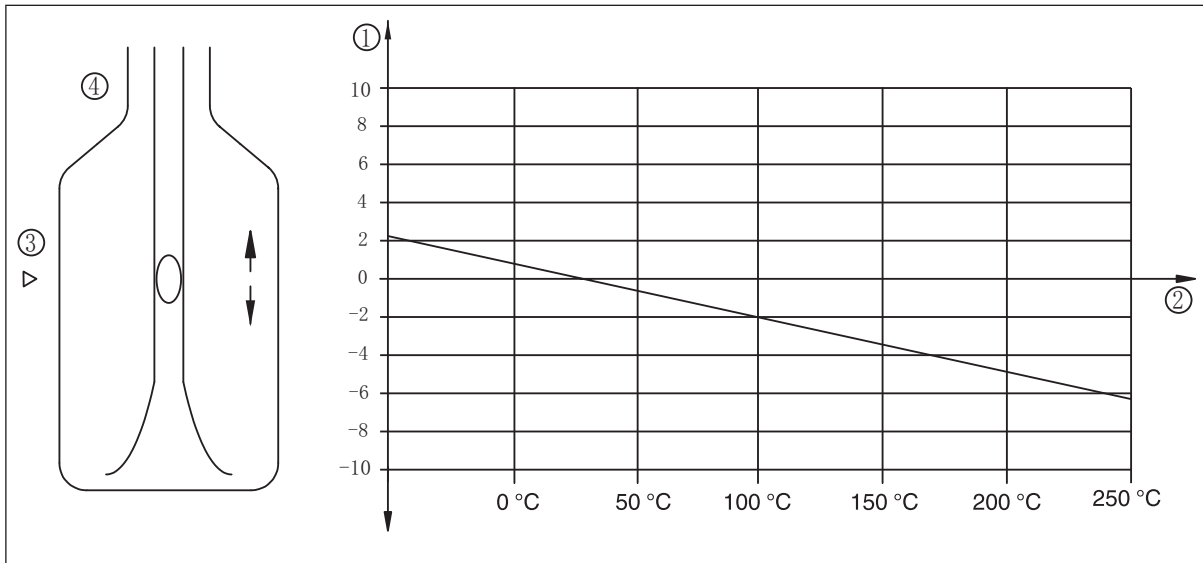

Figure 15 effect of process temperature on switching point

- ① Move switch point, move distance in mm
- ② Process temperature, measured in °C
- ③ The switch point under the reference condition
- ④ Tuning Fork body

Effect of medium density on switching point

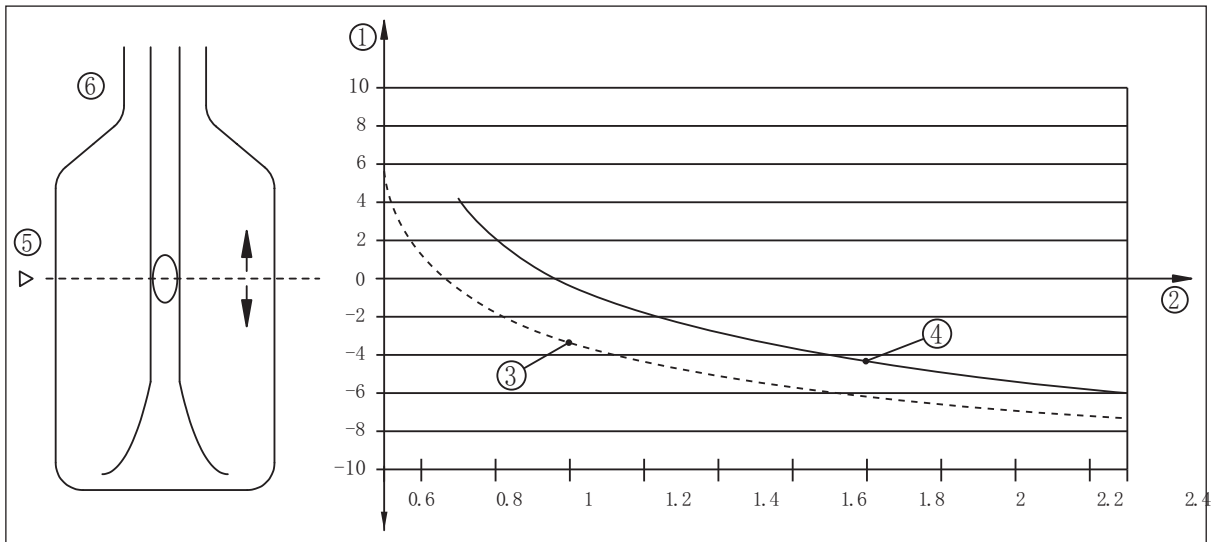

Figure 16 effect of dielectric density on switching point

- ① Move switch point, move distance in mm
- ② Medium density, g/cm³
- ③ The switch position is 0.5 g/cm³
- ④ The switch position is 0.7 g/cm³
- ⑤ The switch point under the reference condition
- ⑥ Tuning Fork

Effect of process pressure on switching point

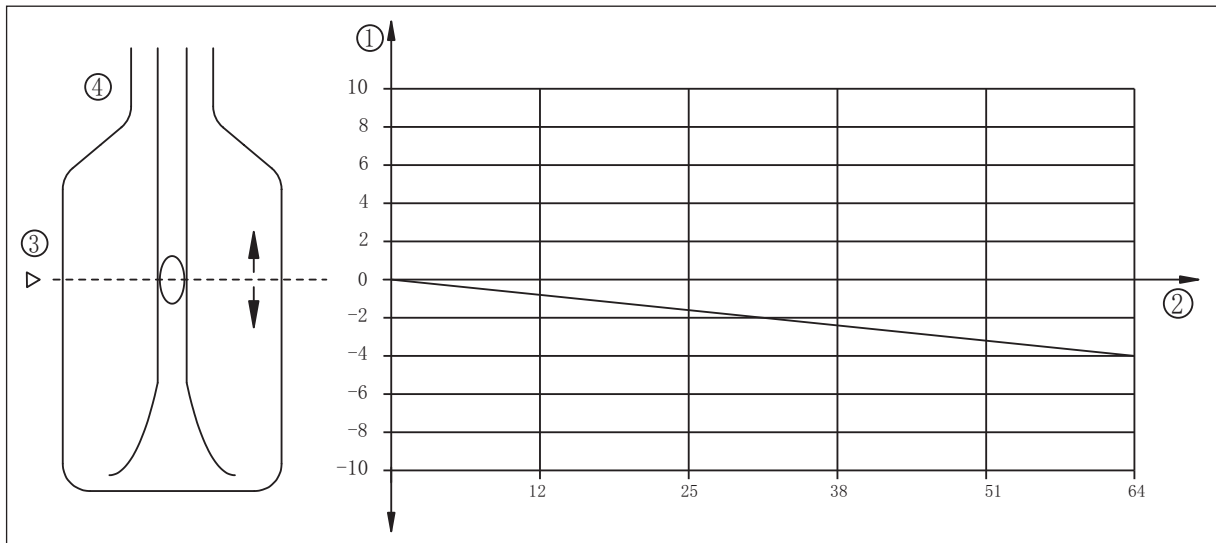

Figure 17 effect of process pressure on switching point

- ① Move switch point, move distance in mm
- ② Process pressure, measured in bar
- ③ The switch point under the reference condition
- ④ Tuning Fork body

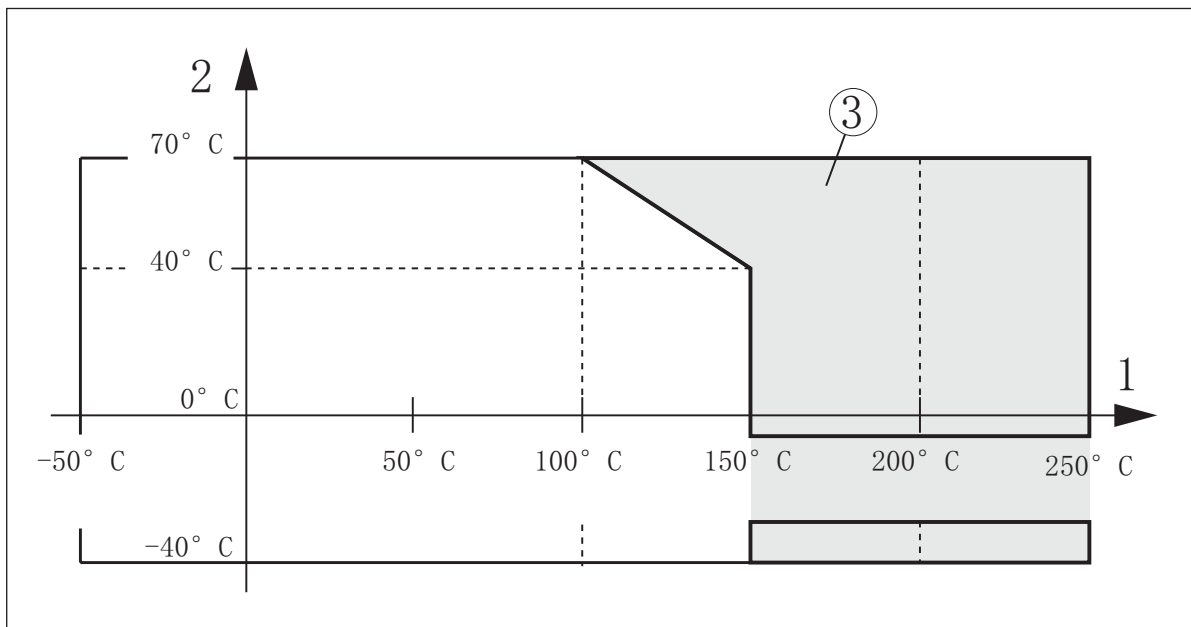

Figure 18 ambient temperature-process temperature

- ① Process temperature, measured in °C
- ② Ambient temperature, measured in °C
- ③ Temperature range with temperature connection element

9. Transport And Storage

In addition to the requirements of JB/T 9329, the transport and storage conditions of level transmitter shall be in accordance with the following requirements:

1. The material level Transmitter should be transported strictly according to the characteristics of the products and the requirements of the specifications.
2. The level gauge shall be stored in a dry ventilated room at $-20 \sim 60^{\circ}\text{C}$ with a relative humidity of not more 80% . Not to be mixed with corrosive substances. After long-term storage of the instrument should be carried out the corresponding test before sale, use.



Address: 7191 Yonge street, Toronto, Canada

Tel: +16472221281(5 line)

Web: www.madecotech.com

Email: Info@madecotech.com